

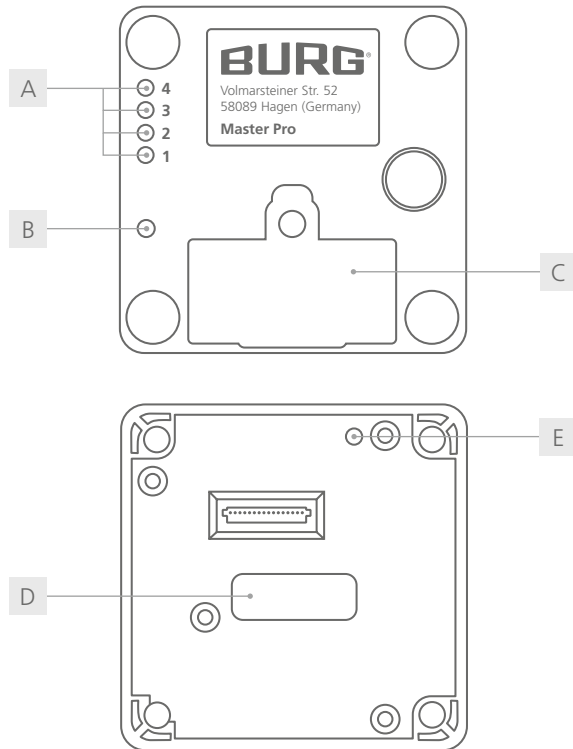

MasterPro Operating Manual

MasterPro



- A programming buttons
- B LED
- C battery compartment
- D version number
- E reset button

General

The latest version of this guide is available at:
www.burg.de

Important notes:

- Please observe all important notes and read the entire operating manual before starting the configuration.
- Before putting the locking system into operation, refer to "Commissioning" on page 5 and check the battery capacity. (For help, see "Battery warning" on page 5.)
- Master cards must be kept in a safe place. If lost, no further configurations can be made.
- The lock is not suitable for installation in steel furniture.
- Note that the reset button is located on the back side of the lock and can only be operated when the lock is disassembled.

Content

General.....	2
Technical data.....	3
Default settings.....	3
Scope of delivery.....	3
Optional accessories.....	3
Features.....	4
Mounting dimensions.....	4
Product dimensions.....	4
Functional description.....	5
LED & sound signals.....	5
Guarantee of transponder compatibility.....	5
Commissioning.....	6
Configuration.....	6 - 7
Operation.....	7
Assembly.....	8
Battery change.....	9
Disposal and battery note.....	10
Information on battery life.....	10
Conformity / Certification.....	10
Guarantee and warranty.....	10
Cleaning and care instructions.....	10
Contact.....	10
MasterPro drilling template.....	11

To the video:
operation



To the video:
assembly



For online viewing, click on QR codes.

Factsheet

Front view



Back view



Technical Data

Dimension	operating unit: 61 x 61 x 22 mm locking angle: 61 x 22 x 17 mm
Battery ¹	VARTA ¹ CR123A (1x)
Locking cycles	up to 30.000 ²
Material	housing: plastic locking bolt: acrylic and steel
Humidity (rel.)	10% - 85%
Temperature range	working temperature: -10°C to 50°C storage temperature: -20°C to 65°C
Degree of soiling	2
IP class	IP30
Application area	Indoor
Mounting dimension	(see p. 4 "Mounting dimensions")
Max. door thickness	25 - 30 mm
Lock attachment	wood screw M4 x 30 mm (4x), wood screw M4 x 25 mm (2x),
Break-off value	45N ³
Locking direction	left (90°), door hinge: DIN right right (90°), door hinge: DIN left
Mode 1	multi-user mode (default),
Mode 2	private mode (automatic locking),
Mode 3	private mode (manual locking)
RFID types ⁴	MIFARE® Classic (read / write)
No. of master cards	max. 3
No. of manager cards	max. 3
No. of user cards	max. 30
No. of delete cards	max. 7

Default Settings

Mode	multi-user mode
Signal sounds	on

Scope of Delivery

- 1x locking system (operating unit and locking angle)
- 4x wood screw (M4 x 30 mm)⁵
- 2x wood screw (M4 x 12 mm)⁵
- 1x battery compartment screw (2 x 4 mm)⁵, pre-assembled
- 1x Battery compartment screw Knurled screw, self-turning (2 x 10 mm)
- 1x RFID card (MIFARE® Classic)

Optional Accessories

- battery (VARTA¹ CR123A)
- master card
- manager card
- user card
- delete card

¹ The lock is approved for VARTA brand batteries. The use of other batteries may lead to malfunctions (s. point „battery note“).

² Test value for consecutive locking cycles with one set of VARTA batteries. In everyday use, factors such as usage profile, temperature-dependent self-discharge, battery quality, and the standby current of the electronics limit the achievable number of cycles. The actual number may therefore vary. For further information, see p. 10 "Information on battery life".

³ The specified value may vary depending on the installation situation and the thickness of the door.

⁴ Please note the point "Guarantee of transponder compatibility" (s. p. 5)

⁵ The use of a screw with a different length may cause damage to the lock.

Features

- invisible on the door front
- proven RFID technology (MIFARE® Classic)
- up to 30 user cards can be assigned in private mode
- integrated occupancy identification in multi-user mode
- compact size (61 x 61 x 22 mm)
- option for LED signaling on the front via light pipes

Mounting Dimensions ¹

All dimensions are in millimeters.

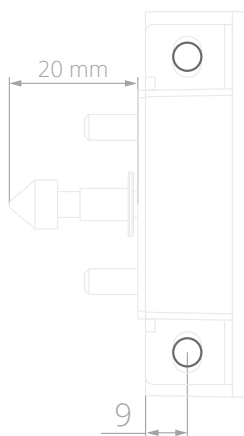
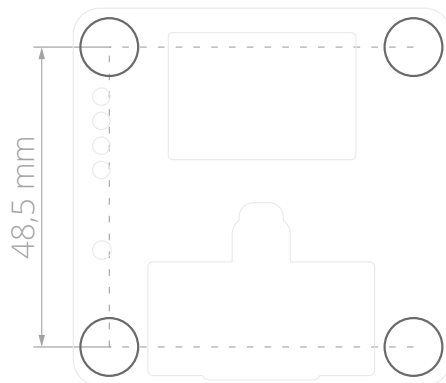

Product Dimensions ¹

Operating unit

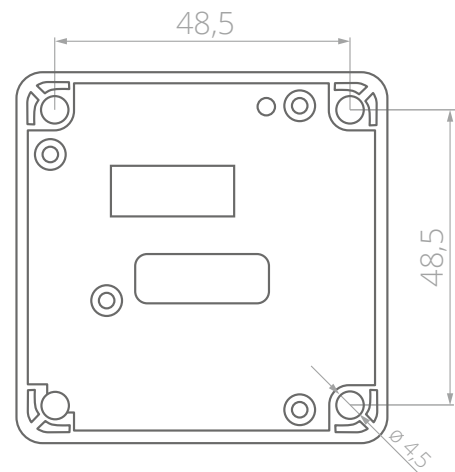
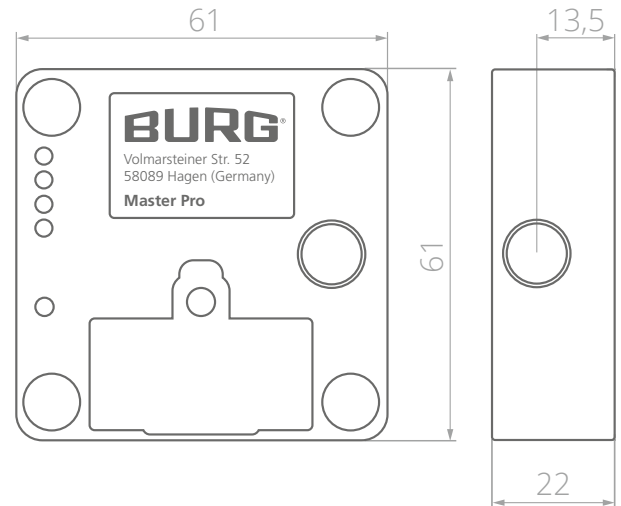

Locking angle

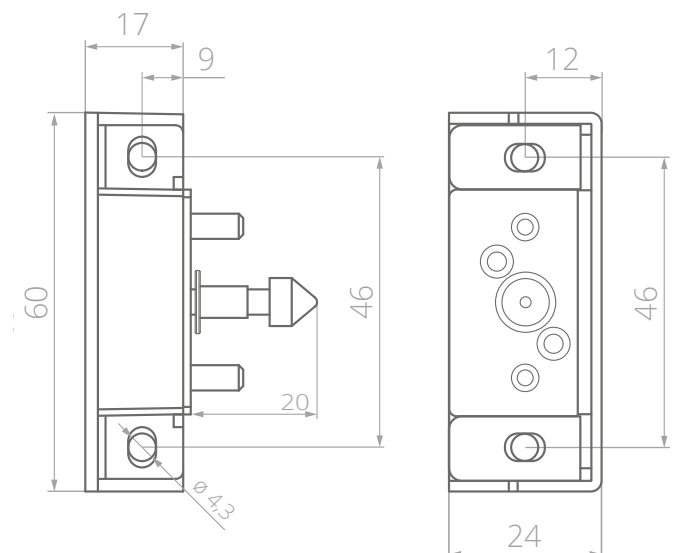

¹ Mounting dimensions and templates (STEP files) for milling, punching or lasering can be requested from BURG. Valid for all versions from production date 02-2022. The version date is located on the back of the locking system.

Functional Description

Mode 1: multi-user authorization (multi-user mode)

This mode is suitable for changing user groups where the locker is only used temporarily or once, e.g. in a sports facility. Transponder media are valid for a single locking process and are deleted from the lock when the compartment is reopened. The lock remains open until a new transponder medium locks the lock again.

Mode 2: fixed assigned authorization (private mode)

Automatic locking

In this mode, a transponder medium is preset with which the lock can be operated. This mode is suitable for user groups where the usage rights should not change permanently, e.g. for an office cabinet. The lock can only be operated with a stored transponder medium. Transponder media that are not stored are rejected by the lock.

After opening, the lock closes automatically after a few seconds. The door must be closed again within 30 seconds after opening. If the door is not closed within this time, a 10-second alarm tone sounds.

Modus 3: fixed assigned authorization (private mode)

Manual locking

In this mode, a transponder medium is preset with which the lock can be operated. This mode is suitable for user groups where the usage rights should not change permanently, e.g. for an office cabinet. The lock can only be operated with a stored transponder medium. Transponder media that are not stored are rejected by the lock.

The lock remains open until the transponder medium closes it again.

Master card

The master card can open the lock regardless of the set mode (emergency opening) and end the block mode. After opening, the lock remains in the open state. In multi-user mode, the transponder medium used for locking is deleted from the lock.

Manager card

The manager card authorizes the programming of transponder media in private mode (mode 2 and mode 3). In addition, the manager card can temporarily open the lock in multi-user mode (mode 1) without deleting the transponder media used for locking the lock².

Delete card (private mode, mode 2 and 3)

The delete card authorizes the deletion of stored transponder media. Master and manager cards are not deleted during this process.

Automatic locking (for private mode, mode 2)

After opening, the lock closes automatically after a few seconds. The door must be closed again within 30 seconds of opening. If the door is not closed within this time, a 10-second alarm sounds.

Occupancy identification (multi-user mode, Mode 1)

During the locking process, the transponder medium used for locking is assigned an occupancy identification. The occupancy identification prevents the transponder medium from locking another lock. The occupancy identification is canceled again during the opening process.

Note: This function is only possible with MIFARE® Classic transponder media. The occupancy identification can also be deleted from the transponder medium using the master card or the release box (e.g. after opening with a master card or manager card).

Battery warning

If the battery voltage falls below a certain level (phase 1), 8 short signal sounds will sound when a transponder medium is held up, and the blue LED will light up. The lock can still be operated. If the voltage continues to fall (phase 2), the lock can no longer be operated and can only be opened with the master card.

Block Mode

If an unauthorized transponder medium is held in front of the lock five times in succession, the lock will lock for 60 seconds. During this period, the lock cannot be operated. Transponder media are rejected with an audible signal and the red LED lights up. Holding up the manager card ends the block mode.

Status Alarm

When automatic locking is activated, the door must be closed within 30 seconds of opening. If the door is not closed within this time, a 10-second alarm will sound.

LED & Signal Sounds

LED ● ● ● + 1x signal sound

Successful switch to mode 1.
Successful opening/closing process.

LED ● ● ● ● + 2x signal sounds

Successful switch to mode 2.

LED ● ● ● ● ● + 3x signal sounds

Successful switch to mode 3.
Successful reset of the lock.

LED ● ● ● + 2x signal sounds

Rejecting unauthorized transponders.

Guarantee of Transponder Compatibility

When using RFID transponder media that have not been approved by BURG, no guarantee of compatibility is given.



Commissioning

We recommend to assign a master card and a manager card during commissioning.

1 First steps

1. Remove the lock from the packaging and open the battery compartment. (Help on p. 9 " Battery change").
2. Insert batteries according to the (+ / -) symbols. Wait for the sound signal and the green LED to light up. Close the battery compartment.
3. Programming master card and manager card. (Chapter: Configuration, Section 2 Cards "Master Card" and "Manager Card")

Configuration

Unauthorized cards are rejected by the lock with two sound signals and the LED sequence    rejected.

1 Change mode

During this process, all user cards and delete cards are deleted from the lock.

Press programming button 3 for two seconds. The signal sounds and the green LED confirm that the process was successful.

1. 2x signal sounds:
Switch from mode 1 (default) to mode 2.
2. 3x signal sounds:
Switching from mode 2 to mode 3.
3. 1x signal sound:
Switching from mode 3 to mode 1.

2 Assign cards

a) Master card

1. Press programming button 4 for two seconds. The green LED will start flashing.
2. Hold the master card to be assigned in front of the lock. A sound signal confirms the successful process.
3. If necessary, hold additional master cards in front of the lock while it is flashing.
4. Wait until the LED stops flashing.

Note: A total of 3 master cards can be assigned.

b) Manager card

1. Press programming button 1 for two seconds. The green LED will start flashing.
2. Hold the manager card to be assigned in front of the lock. A sound signal confirms the successful process.
3. If necessary, hold additional manager cards in front of the lock while it is flashing.
4. Wait until the LED stops flashing.

Note: A total of 3 manager cards can be assigned.

c) Delete card (mode 2 and Modus 3)

1. Press programming button 2 for two seconds. The green LED will start flashing.
2. Hold the delete card to be assigned in front of the lock. A sound signal confirms the successful process.
3. If necessary, hold additional delete cards in front of the lock while it is flashing.
4. Wait until the LED stops flashing.

Note: A total of 7 delete cards can be assigned.

d) User card (mode 2 and mode 3)

1. Hold the manager card in front of the lock. The green LED will start flashing.
2. Hold the user card to be assigned in front of the lock. A sound signal confirms the successful process.
3. If necessary, hold additional user cards in front of the lock while it is flashing.
4. Wait until the LED stops flashing.

Note: A total of 30 delete cards can be assigned.

3 Delete user cards (mode 2 and mode 3)

This process deletes **all** stored transponder media from the lock.

1. Hold the delete card in front of the lock. A sound signal and the green LED confirm the successful process.

4 Delete occupancy identification from user card

The **Release Box** is required for this process. The user card can be used again after deletion.

1. Hold the user card centrally on the release box.
2. A beep and the green and then the blue LED¹ confirm the successful process.

5 Reset to default settings

The lock must be disassembled for this process (see page **8**, "Assembly" for help). All settings will be reset to their default settings. All programmed cards and transponder media will be deleted.

1. Disassemble the operating unit.
2. Press the reset button for a few seconds.
3. Three signal sounds and the green LED flashing three times confirm the successful process.

Operation

Unauthorized cards are rejected by the lock with two continuous signal sounds and the red LED flashing twice.

1 Multi-user mode

a) Lock

1. Close door.
2. Hold the user card in front of the lock. A signal sound and the green LED confirm the successful process.

b) Unlock

1. Hold the user card in front of the lock. A signal sound and the green LED confirm the successful process.
2. Open the door.

2 Private mode

a) Unlock

1. Hold the user card in front of the lock. A signal sound and the green LED confirm the successful process.
2. Open the door.

b) Lock (mode 2)

The lock closes automatically within a few seconds. The green LED flashes shortly and a signal sounds. To close, push the door shut within 30 seconds.

c) Lock (mode 3)

1. Close door.
2. Hold the user card in front of the lock. A signal sound and the green LED confirm the successful process.

3 Unlock via master card / manager card

During this process, the user card used for closing is deleted from the lock in multi-user mode.

1. Hold the master card / manager card in front of the lock. A signal sound and the green LED confirm the successful process.
2. Open the door.

Assembly

- Mounting dimensions and templates (STEP files) for milling, punching or lasering can be requested from BURG.
- **Not suitable for installation in steel furniture.**
- When installing multiple locking systems next to each other, a minimum distance of at least 15 cm vertically and at least 5 cm horizontally must be maintained. There must be no metal objects within a radius of at least 20 cm. If the lock is damaged due to improper installation, the manufacturer's warranty will be void.
- For installation, refer to the drilling template and installation instructions in the appendix to the operating instructions.

- 1 Locate the position of the operating unit and the locking angle. To assist you, it is advisable to mark the specified positions with a pencil.

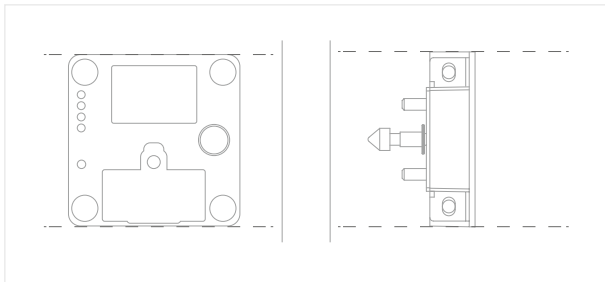

- 2 Prepare the mounting holes on the door front according to the installation dimensions (dimensions on p. 4). Mark the correct position of the operating unit (inside of the door) and the locking angle (inside of the cabinet) and pre-drill the screw holes if necessary.

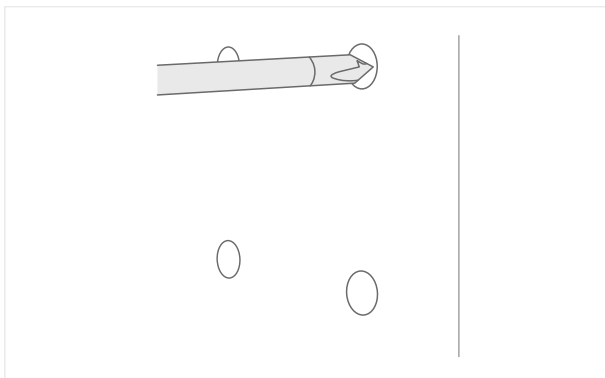

- 3 Position the operating unit according to the markings and screw it to the door front using a cross-head screwdriver and the wood screws (M4 x 30 mm). Position the screws diagonally and then tighten them.

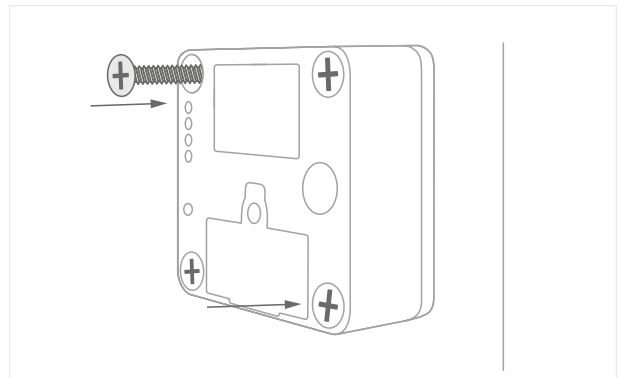
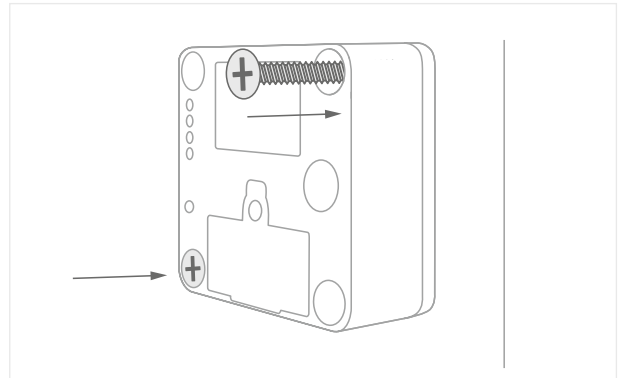

- 4 Position the locking unit according to the markings and secure it to the inside of the cabinet using a cross-head screwdriver and the 2 wood screws (M4x25). The operating unit and the locking unit must be adjusted so that the door can be closed without pressure and the bolt can be fully extended without any problems.

Note: The locking unit has two spring-loaded metal pins that help the locking system to push the door front open easily. Door hinges with counterpressure can restrict this function and prevent the locking system from opening smoothly. It is recommended to use only door hinges without counterpressure springs.

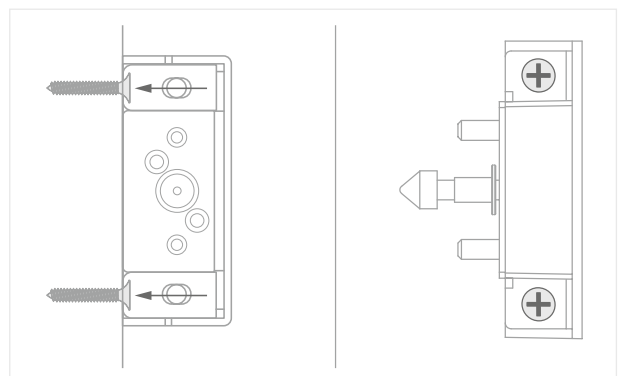

Battery Change

The lock must be dismantled to replace the battery. A **cross-head screwdriver** is required to open the battery compartment. Alternatively, the self-turning screw (see scope of delivery) can also be used to close the battery compartment cover.

- 1 Carefully loosen the battery compartment screw using the cross-head screwdriver or loosen the self-turning screw with your fingers. Remove the battery compartment cover.

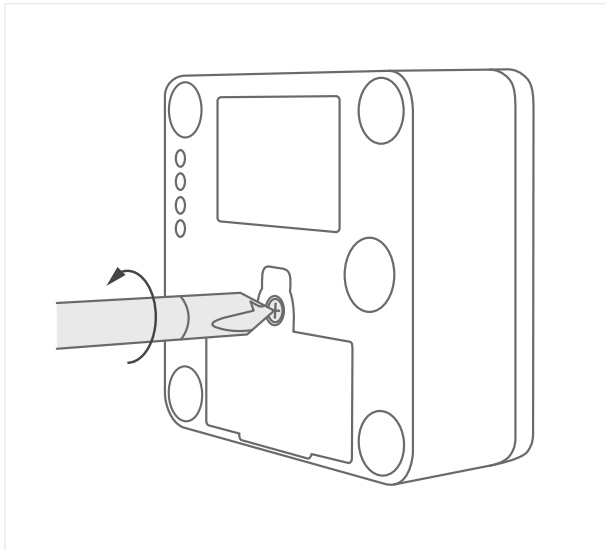

- 2 Replace the battery according to the (+/-) symbols and close the battery compartment cover.

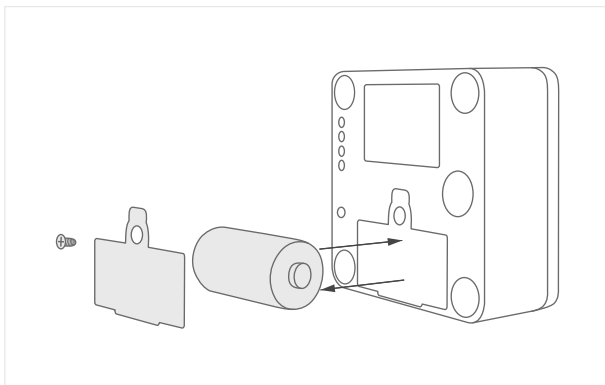

- 3 Tighten the battery compartment screw using the cross-head screwdriver or tighten the self-tightening screw with your fingers.

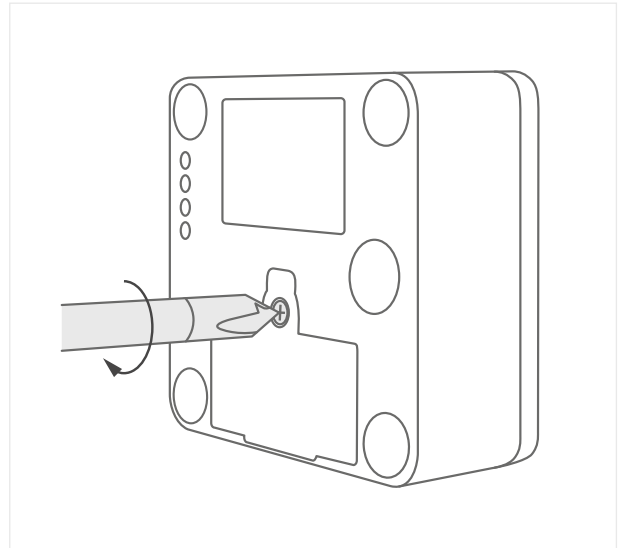

Disposal and Battery Note

EU Directive 2012/19/EU regulates the proper take-back, treatment and recycling of used electronic devices.

Every consumer is legally obliged to dispose of batteries, rechargeable batteries or electrical and electronic devices ("old devices") that are powered by batteries or rechargeable batteries separately from household waste, as they contain harmful substances and valuable resources. They can be disposed of at an approved collection or take-back point, e.g. a local recycling center. Old appliances, batteries and rechargeable batteries are accepted there free of charge and recycled in an environmentally friendly and resource-saving manner. Old electrical appliances, used batteries or rechargeable batteries can also be returned to us. The return shipment must be sent with sufficient postage to the address below. The following symbol on waste electrical equipment, batteries or rechargeable batteries indicates that they must not be disposed of with household waste:



Important notes on the use of batteries:

- The use of high-quality brand batteries is essential for the correct functioning of the locking system. BURG locking systems are approved ex works for the specified industrial batteries of the VARTA brand. The use of batteries of other brands can lead to a reduced number of possible locking cycles as well as to limited functionality and functional problems, as experience has shown that batteries of other brands even with the same specifications have different performance characteristics. BURG does **not guarantee** the functionality of the locking system when using batteries of a brand other than those specified above.
- If both batteries are removed at the same time when changing the batteries or over a longer period of time, settings relating to the integrated real-time clock (RTC) will be lost.
- The battery may explode or release flammable gases if it is handled incorrectly, destroyed or the wrong type of battery is used. Do not recharge the battery, disassemble it, expose it to extremely high temperatures or throw it into a fire. Batteries containing harmful substances are labeled with abbreviations for the substances cadmium (*Cd*), mercury (*Hg*) and lead (*Pb*). If the lock is not used for a longer period of time, the batteries must be removed.

Information on battery life



For online viewing,
click on QR codes.

Conformity / Certification

CE Declaration of Conformity

Hereby, **BURG Lüling GmbH & Co. KG** declares that the radio equipment, type **MasterPro**, is in conformity with directives 2014/53/EU and 2011/65/EU. The full text of the EU Declaration of Conformity can be found at the following link:

https://www.burg.de/files/downloads/Declaration-of-Conformity/BURG_DoC_MasterPro_EN.pdf

Guarantee and Warranty

The warranty is subject to the statutory provisions. If you have any questions, please contact a specialist dealer or use the contact details below. Spare parts can be found at specialist dealers or at: **www.burg.shop**

Cleaning and Care Instructions

Remove the batteries before cleaning the appliance. Carefully clean the surfaces of the appliance with a damp, clean cloth. Chemical cleaning agents must not be used. Do not allow dust or liquids to enter the device.

Kontakt

BURG Lüling GmbH & Co. KG

Volmarsteiner Str. 52
58089 Hagen (Germany)
+49(0)23 35 63 08-0

info@burg.de
www.burg.de

MasterPro Bohrvorlage MasterPro drilling template

Bedieneinheit

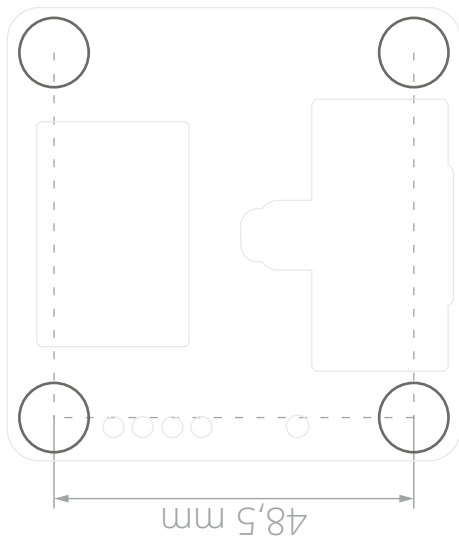

Türkante / door edge

Der Abstand zwischen Türkante und Befestigungsposition ist abhängig von der Türposition:
The distance between the door edge and the installation position depends on the door position:

Innenliegende Tür (Tür sitzt im Korpus)
Internal door (door sits in the body)

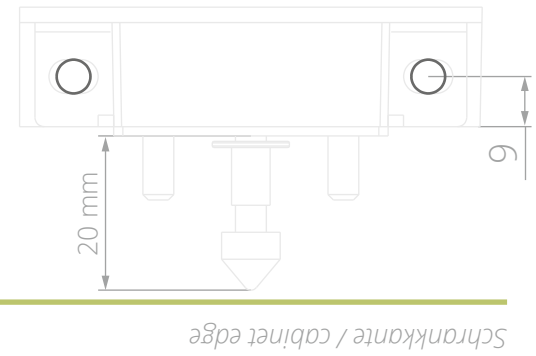
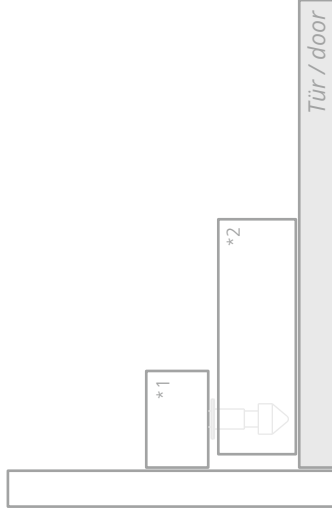

Schließwinkel

Aufliegende Tür (Tür sitzt vor dem Korpus) =
Internal door (door sits in front of the body)

