



Flexo.RFID  
Operating Manual



reddot winner 2023



GERMAN  
DESIGN  
AWARD  
WINNER  
2024

## Flexo.RFID

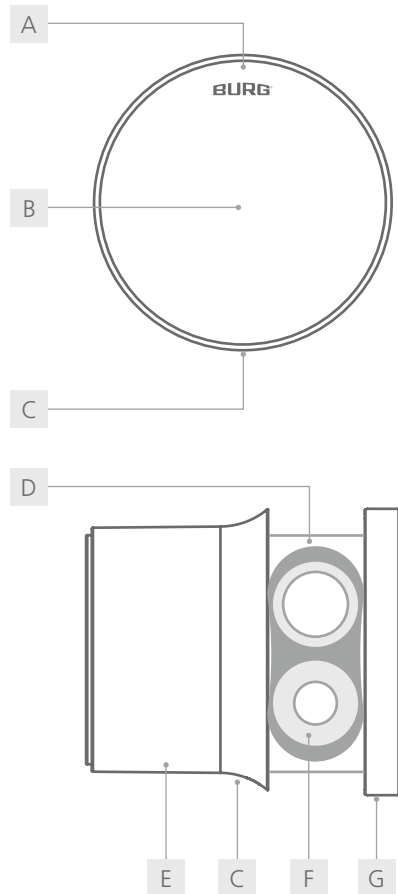

- |                   |                       |
|-------------------|-----------------------|
| A LED             | B RFID antenna        |
| C closure hole    | D battery compartment |
| E housing         | F battery             |
| G operating panel |                       |

## General

The latest version of this guide is available at:  
[www.burg.de](http://www.burg.de)

### Important notes:

- Please observe all important notes and read the entire operating manual before starting the configuration.
- Before putting the locking system into operation, refer to "Commissioning" on page 6 and check the battery capacity. (For help, see "Battery warning" on page 5.)
- Master cards must be kept in a safe place. If lost, no further configurations can be made.

## Content

General.....	2
Technical data.....	3
Default settings.....	3
Scope of delivery.....	3
Optional accessories.....	3
Features.....	3
Mounting dimensions.....	4
Product dimensions.....	4
Functional description.....	5
LED- and sound signals.....	5
Guarantee of transponder compatibility.....	5
Commissioning.....	6
Configuration.....	6 - 7
Operation.....	8
Assembly RetroFit.....	9
Assembly FlushFit.....	10
Battery change with Flexo.Tool.....	11
Battery change with opening needle.....	12
Disposal and battery note.....	13
Information on battery life.....	13
Conformity / Certification.....	13
Guarantee and warranty.....	13
Cleaning and care instructions.....	13
Contact.....	13

To the video:  
**operation**



To the video:  
**assembly (FlushFit)**



To the video:  
**assembly (RetroFit)**

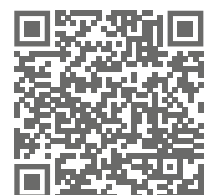

For online viewing, click on QR codes.

# Factsheet

Front view



Back view

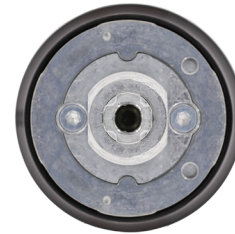

Technical Data	
Dimension	Ø 50 mm
Battery <sup>1</sup>	VARTA <sup>1</sup> 1/2 AAH-R (2x) 850 mAh, CR High Power
Locking cycles	up to 25.000 <sup>2</sup>
Material	housing: plastic stator: zamak
Humidity (rel.)	10% - 80%
Temperature range	working temperature: 0°C to 55°C storage temperature: -20°C to 70°C
Degree of soiling	2
IP class	IP30
Application area	indoor
Mounting dimension	RetroFit: 16 mm x 19 mm FlushFit: 44,55 mm x 46,5 mm
Max. door thickness	22 mm
Lock attachment	RetroFit: M19 nut (1x) FlushFit: Flexo.Nut (1x)
Cam type	B
Locking direction	left (90°), door hinge: DIN right right (90°), door hinge: DIN left
Mode	multi-user mode (default), private mode
RFID types	MIFARE® Classic (read / write), MIFARE® DESFire® EV (read)
No. of master cards	max. 3
No. of manager cards	max. 2
No. of user cards	max. 10

Default Settings	
Mode	multi-user mode
Occupancy identification	on

- Scope of Delivery**
- 1x locking system
  - 1x cam fixing screw <sup>3</sup> (M6 x 12 mm)
  - 1x M19 nut (Assembly: RetroFit)
  - 1x Flexo.Ring (mounted) / Flexo.Nut (Assembly: FlushFit)

- Optional Accessories**
- Battery (VARTA <sup>1</sup> 1/2 AAH-R)
  - anti-twist protection (W-MSZ-01)
  - master card / manager card (assigned)
  - user card
  - function card „mode switch“
  - function card „reset“
  - sector card set (sector 0 to sector 15)
  - opening needle / Flexo.Tool
  - cam type B (order-related)

- Features**
- ergonomic handling and high-quality design
  - external battery access and battery change
  - RFID types: MIFARE® Classic / MIFARE® DESFire® EV
  - integrated occupancy identification with MIFARE® Classic
  - easy to retrofit, e.g. to replace mechanical locks
  - adjustable cam (in 90° steps)

<sup>1</sup> The lock is approved for VARTA brand batteries. The use of other batteries may lead to malfunctions (s. point „battery note“).

<sup>2</sup> Test value for consecutive locking cycles with one set of VARTA batteries. In everyday use, factors such as usage profile, temperature-dependent self-discharge, battery quality, and the standby current of the electronics limit the achievable number of cycles. The actual number may therefore vary. For further information, see p. 13 "Information on battery life".

<sup>3</sup> The use of a screw with a different length may cause damage to the lock.

## Mounting Dimensions <sup>1</sup>

All dimensions are in millimeters.

FlushFit

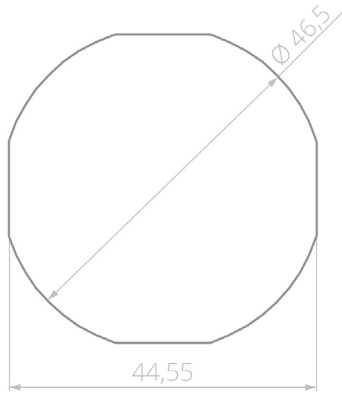

RetroFit

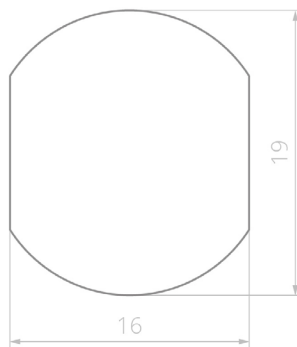

## Product Dimensions <sup>1</sup>

Frontview

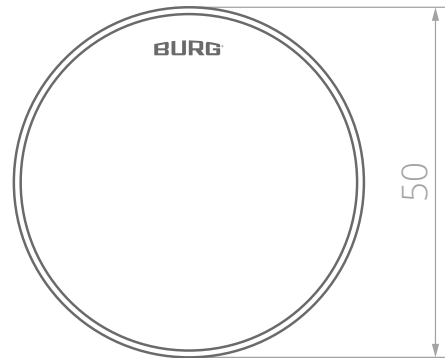

Sideview

FlushFit

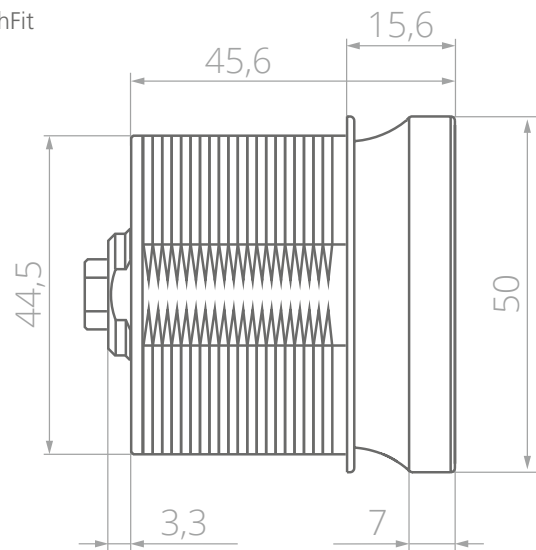

RetroFit

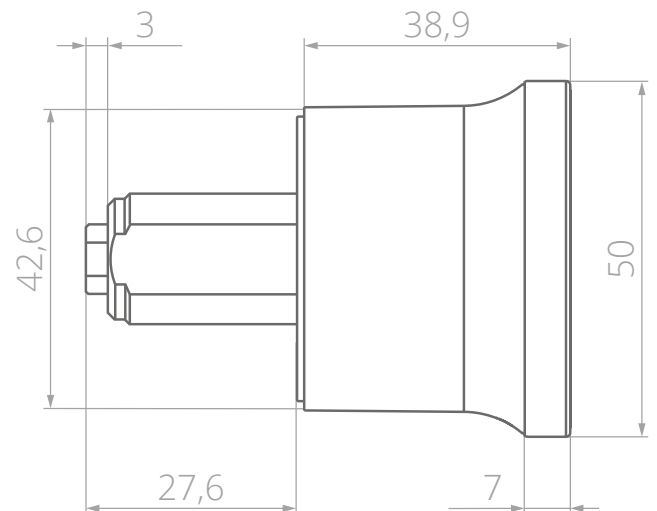

<sup>1</sup> Mounting dimensions and templates (STEP files) for milling, punching or lasering can be requested from BURG.

## Functional Description

For operation with MIFARE® DESFire® EV transponders, the occupancy identification must be deactivated (chapter: Configuration, point 4c "Deactivate occupancy identification")

### Mode: multi-user authorization (multi-user mode)

This mode is suitable for changing user groups where the locker is only used temporarily or once, e.g. in a sports facility. Transponder media are valid for a single locking process and are deleted from the lock when the compartment is reopened. The lock remains open until a new transponder medium locks the lock again.

### Mode: fixed assigned authorization (private mode)

In this mode, a transponder medium is preset with which the lock can be operated. This mode is suitable for user groups where the usage rights should not change permanently, e.g. for an office cabinet. The lock can only be operated with a stored transponder medium. Transponder media that are not stored are rejected by the lock.

### Master card

The master card can open the lock regardless of the set mode (emergency opening). In multi-user mode, the transponder medium used for locking is deleted from the lock. The master card also authorizes the programming of master, manager and user cards (in private mode).

### Occupancy identification (for multi-user mode)

During the locking process, the transponder medium used for locking is assigned an occupancy identification. The occupancy identification prevents the transponder medium from locking another lock. The occupancy identification is canceled again during the opening process.

*Note: This function is only possible with MIFARE® Classic transponder media. The occupancy identification can also be deleted from the transponder medium using the release box (e.g. after opening with a master card or manager card).*

### Manager card

The manager card can unlock the lock regardless of the set mode (emergency opening).

### Mode card

The mode card can be used to change the mode (multi-user mode / private mode).

### Reset card

The reset card deletes all cards and transponder media (master cards, manager cards and user cards).

*Note: The reset card can only be used when the lock is unlocked.*

### LED locking indication

If the lock is locked, the red LED flashes at short intervals.

### Automatic locking (for private mode)

After unlocking, the lock locks automatically after a few seconds. The latch function allows the door to be closed by pressing slightly.

### Battery warning

If the battery voltage falls below a certain level (*phase 1*), three descending beeps sound when a transponder medium is presented. The lock can still be operated. If the voltage drops further (*phase 2*), the lock can no longer be locked. If the voltage falls into the critical range (*phase 3*), the lock can no longer be operated.

## LED- & Tonsignale

### Green LED (brief flash) / 🔊 (increasing)

Acceptance of authorized transponder media.  
Successful opening / configuration process.

### Green LED (flashing)

The lock is in configuration mode.

### Red LED (brief flash)

Successful closing process.  
Successful mode change to private mode.

### Red LED (flashing)

Closed state.

### Red LED (3x flashing) / 🔊 (3x short)

Canceling a configuration process.

### Red LED (8x flashing) / 🔊 (4x short)

Rejecting unauthorized transponder media.

### 🔊 (3x descending during operation)

Battery power decreases.

## Guarantee of Transponder Compatibility

When using RFID transponder media that have not been approved by BURG, no guarantee of compatibility is given.

## Commissioning

- The first card that is held in front of the lock during commissioning or after deleting the cards / resetting is stored as the **master card**.
- We recommend to assign all 3 master cards during commissioning and keeping the master cards in a safe vplace.

### 1 First steps

1. Remove the lock from packaging and open the battery compartment (for help, see page **11/12** "Battery change").
2. Insert the batteries according to the (+ / -) symbols. Wait for the **green** LED to light up, followed by the **red** LED. Close the battery compartment.
3. Hold the master card to be assigned centrally in front of the knob. A sound signal and the **green** LED confirm the successful process.

*Note: To assign further master cards, follow point 1a - "Further master cards" in the chapter "Configuration".*

## Configuration

Unauthorized cards are rejected by the lock with four short sound signals and the **red** LED flashing **8x**.

### 1 Assign cards

#### a) Further master cards

1. Hold the master card **2x** centrally in front of the knob.
  - 1x - An increasing tone sounds and the **green** LED lights up. The lock is now open.
  - 2x - A short tone will sound and the **green** LED starts flashing.
2. Hold the master card to be assigned in front of the knob. A sound signal confirms the successful process.
3. If required, hold further master cards in front of the knob while flashing.
4. The process ends when the **green** LED stops flashing.

*Note: Max. 3 master cards can be assigned.*

#### b) Manager cards

1. Hold the master card **4x** centrally in front of the knob.
  - 1x - An increasing tone sounds and the **green** LED lights up. The lock is now open.
  - 2x - A short tone will sound and the **green** LED starts flashing.
2. Hold the manager card to be assigned in front of the knob. A sound signal confirms the successful process.
3. If required, hold further manager cards in front of the knob while flashing.
4. The process ends when the **green** LED stops flashing.

*Note: Max. 2 manager cards can be assigned.*

#### c) User cards (private mode)

1. Hold the master card **3x** centrally in front of the knob.
  - 1x - An increasing tone sounds and the **green** LED lights up. The lock is now open.
  - 2x - A short tone will sound and the **green** LED starts flashing.
2. Hold the user card to be assigned in front of the knob. A sound signal confirms the successful process.
3. If required, hold further user cards in front of the knob while flashing.
4. The process ends when the **green** LED stops flashing.

*Note: Max. 10 user cards can be assigned.*

## 2 Delete cards

This process deletes all cards from the lock. Cards cannot be deleted individually. The set mode remains active.

### a) Via reset card

1. Hold the master card **1x** centrally in front of the knob. An increasing tone sounds and the **green** LED lights up. The lock is now open.
2. Hold the reset card **1x** in front of the knob. **2x** sound signals and the **green** LED flashing **2x** confirm the successful process.
3. The process ends when the **green** LED stops flashing.

### b) Via master card

1. Hold the master card **6x** centrally in front of the knob.  
1x - An increasing tone sounds and the **green** LED lights up. The lock is now open.  
2x - A short tone will sound and the **green** LED starts flashing.
2. **1x** sound signal and the **green** LED flashing **1x** confirm the successful process.

## 3 Change mode (via mode card)

During this process, all manager cards and user cards are deleted from the lock.

1. Hold the master card **1x** centrally in front of the knob. An increasing tone sounds and the **green** LED lights up. The lock is now open.
2. Hold the mode card **1x** centrally in front of the knob.  
Private mode - **1x** sound signal and the **red** LED flashing **1x** confirm that the successful process.  
Multi-user mode - **3x** sound signals and the **green** LED flashing **3x** confirm the successful process.

## 4 Set the occupancy identification

### a) Delete occupancy identification from user cards

The **Release Box** is required for this process. The user card can be used again after deletion.

1. Hold the user card centrally on the release box.
2. **1x** sound signal, **1x** the **green** LED and **1x** the **blue** LED<sup>1</sup> confirm the successful process.

### b) Change sector for the occupancy identification

The **sector card set** is required for this process. By default, the occupancy identification is written to sector **15**.

1. Hold the desired sector card (sector cards 1 to 15) in front of the knob.
2. One sound signal is given per sector. A long sound signal confirms the successful process.

### c) Deactivate occupancy identification

The **sector card set** is required for this process.

1. Hold sector card **0** in front of the knob. A long sound signal confirms the successful process.

<sup>1</sup> LED signal may differ for older release boxes.  
Flexo.RFID | 26-02

## Operation

Unauthorized cards are rejected by the lock with four short sound signals and the **red** LED flashing **8x**.

### 1 Multi-user mode

#### a) Lock

1. Close the door. Turn the knob back to the starting position (logo on top).
2. Hold the user card centrally in front of the knob.  
**2x** increasing sound signals and the **red** LED confirm the successful process.

#### b) Unlock

1. Hold the user card centrally in front of the knob.  
**2x** increasing sound signals and the **green** LED confirm the successful process.
2. Turn the knob to the open position and pull the door open.

### 2 Private mode

#### a) Unlock

1. Hold the user card centrally in front of the knob.  
**2x** increasing sound signals and the **green** LED confirm the successful process.
2. Turn the knob to the open position and pull the door open.

#### b) Lock

The lock closes automatically within a few seconds. The **red** LED flashes briefly. To close, push the door shut and turn the knob back to its original position (logo on top) until it clicks into place.

### 3 Unlock via master card / manager card

During this process, the user card used for locking is deleted from the lock in multi-user mode. If the occupancy identification is activated, it can no longer be used until the occupancy identification is canceled. In private mode, the assigned user cards remain stored.

1. Hold the master card or manager card centrally in front of the knob. **1x** increasing sound signal and the **green** LED confirm the successful process.
2. Turn the knob to the open position and pull the door open.

## Assembly RetroFit

Mounting dimensions and templates (STEP files) for milling, punching or lasering can be requested from BURG.

- 1 Prepare the mounting holes on the door front according to the installation dimensions (dimensions on p. 4).

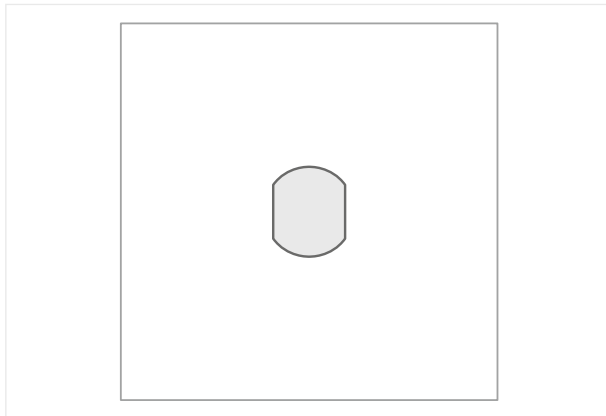

- 2 Insert the lock from the front (outside of the door) into the mounting hole and hold it in this position. The lock must be straight and the BURG logo must be at the top.

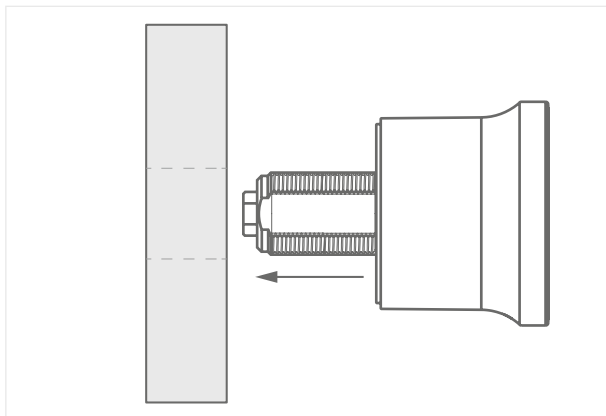

- 3 Place the M19 nut on the stator from behind and tighten it by hand using a socket wrench (SW22).

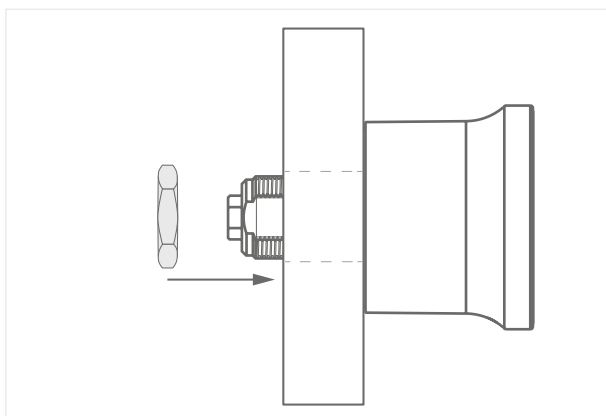

- 4 Attach the cam. Tighten it with the cam fixing screw by hand using a cross-head screwdriver (e.g., size PH 2).

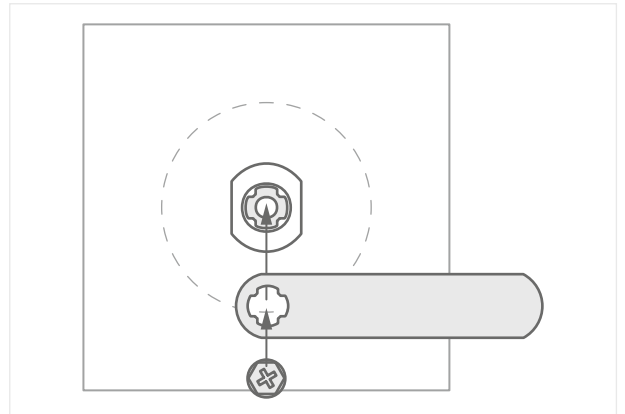

- 5 Check whether the cam is securely held in place on the strike plate or rebate when closed. When closing the locking system, it should be possible to turn the cam to its end position without applying pressure or resistance.

*Note: An adjustable strike plate allows for optimal adjustment of the closing mechanism. More information can be requested from BURG.*

To the video:  
**assembly (RetroFit)**



For online viewing,  
click on QR codes.

## Montage FlushFit

Mounting dimensions and templates (STEP files) for milling, punching or lasering can be requested from BURG.

- 1 Prepare the mounting holes on the door front according to the installation dimensions (dimensions on p. 4).

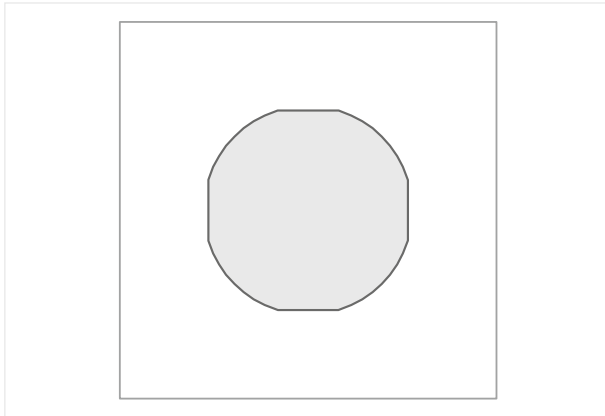

- 2 Insert the Flexo.Ring from the front (outside of the door) into the mounting hole and secure it with the ring nut.

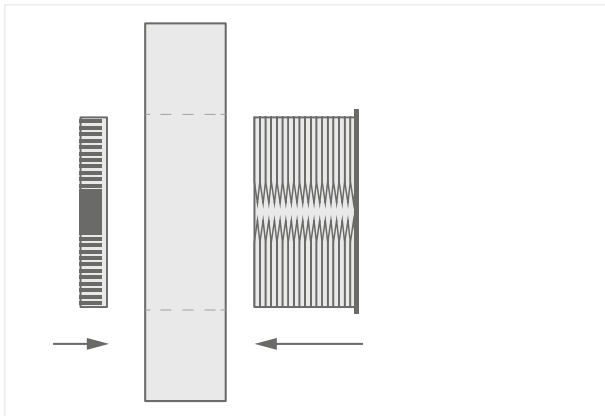

- 3 Insert the lock from the front (outside of the door) into the mounting hole and hold it in this position. The lock must be straight and the BURG logo must be at the top.

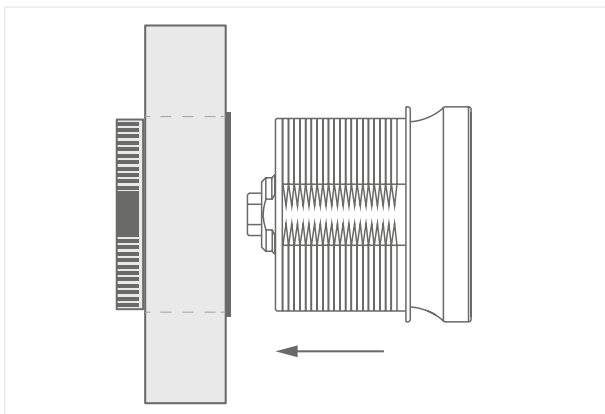

- 4 Place the Flexo.Nut on the stator from behind and tighten it by hand using a socket wrench (SW22).

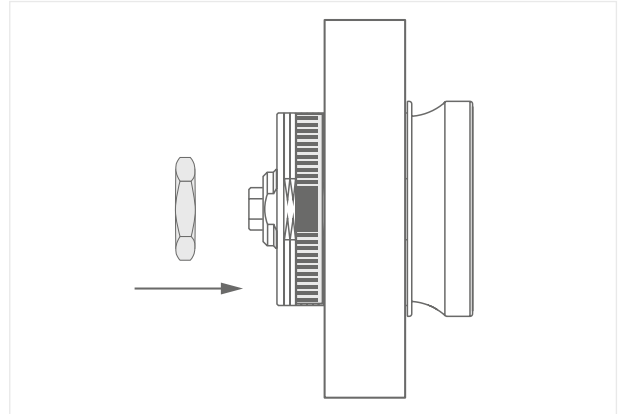

- 5 Attach the cam. Tighten it with the cam fixing screw by hand using a cross-head screwdriver (e.g., size PH 2).

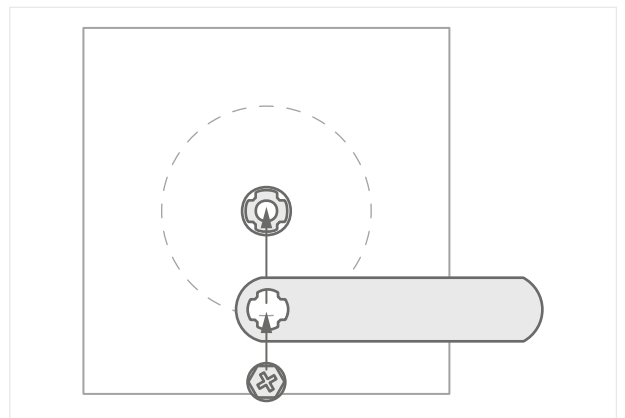

Check whether the cam is securely held in place on the strike plate or rebate when closed. When closing the locking system, it should be possible to turn the cam to its end position without applying pressure or resistance.

*Note: An adjustable strike plate allows for optimal adjustment of the closing mechanism. More information can be requested from BURG.*

To the video:  
**assembly (FlushFit)**



For online viewing,  
click on QR codes.

## Battery Change with Flexo.Tool

The **Flexo.Tool** is required for this battery change option. To open the battery compartment, simply twist the housing (shown as the gray area in the sketches).

- 1 When disassembled, the lock must be held in place on the stator. When assembled, the lock does not need to be held in place.

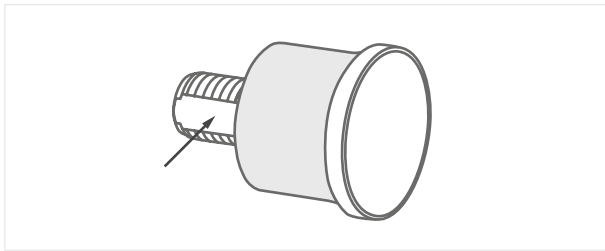

- 2 Carefully insert Flexo.Tool into the hole below the control unit until you feel resistance, then press lightly.

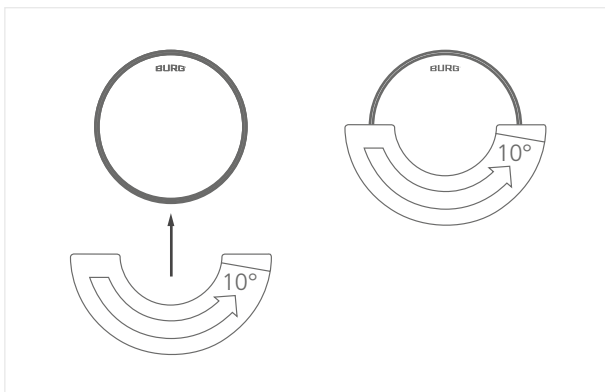

- 3 Hold Flexo.Tool in position and turn the tool with the housing (see sketch 1 above) approximately 10° counterclockwise. The control panel is not turned during this process.

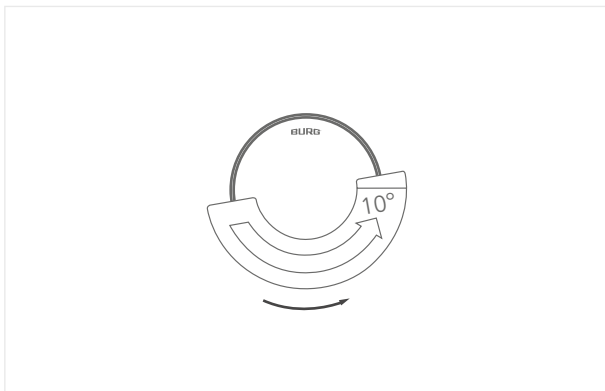

- 4 Remove Flexo.Tool and pull the control panel forward.

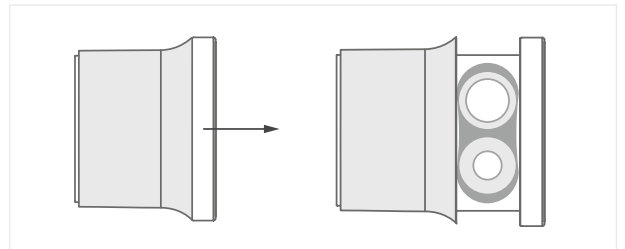

- 5 Remove the battery compartment cover. Replace the batteries according to the (+/-) symbols and replace the battery compartment cover.

- 6 Push the control panel back. Carefully turn the housing clockwise back until it clicks into place.

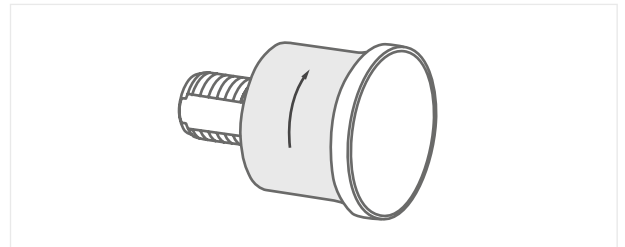

To the video:  
**Battery change**



For online viewing,  
click on QR codes.

## Battery Change with opening needle

The **opening needle** is required for this battery change option. To open the battery compartment, simply twist the casing (shown as the gray area in the sketches).

- 1 When disassembled, the lock must be held in place on the stator. When assembled, the lock does not need to be held in place.

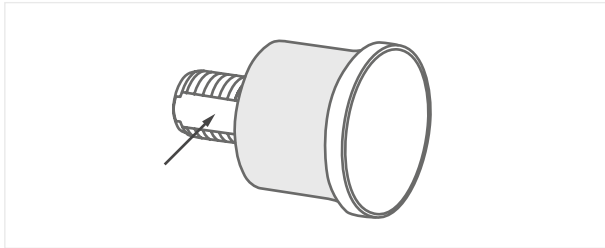

- 2 Carefully insert the opening needle into the hole below the control unit until you feel resistance, then press lightly.

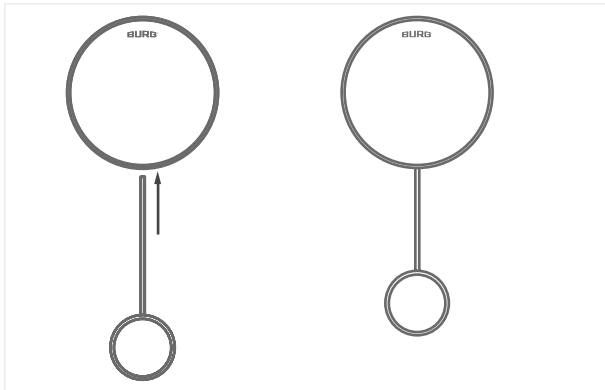

- 3 Hold the opening needle in position and turn the needle with the housing (see sketch 1 above) approximately 10° counterclockwise. The control panel is not turned during this process.

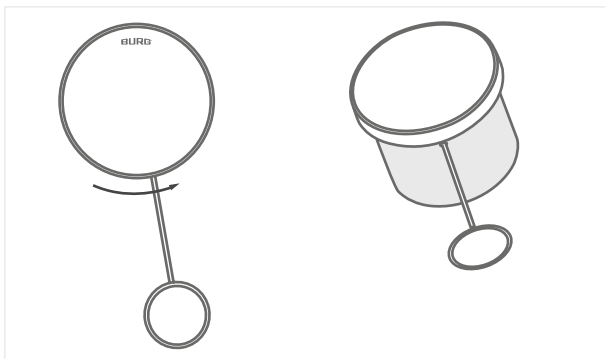

- 4 Remove the opening needle and pull the control panel forward.

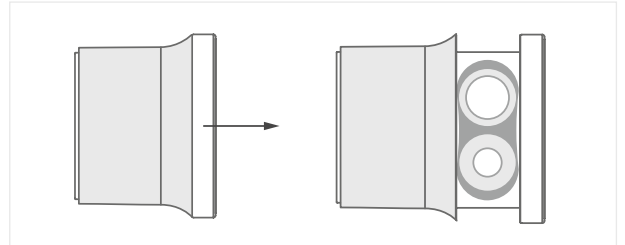

- 5 Remove the battery compartment cover. Replace the batteries according to the (+/-) symbols and replace the battery compartment cover.

- 6 Push the control panel back. Carefully turn the housing clockwise back until it clicks into place.

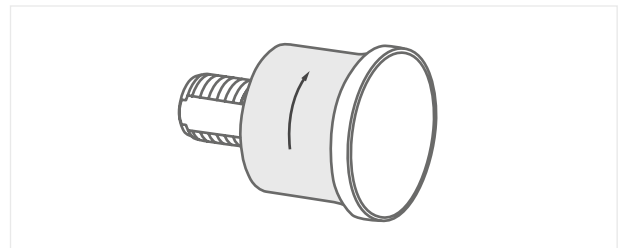

To the video:  
**Battery change**<sup>1</sup>



For online viewing,  
click on QR codes.

## Disposal and Battery Note

EU Directive 2012/19/EU regulates the proper take-back, treatment and recycling of used electronic devices.

Every consumer is legally obliged to dispose of batteries, rechargeable batteries or electrical and electronic devices ("old devices") that are powered by batteries or rechargeable batteries separately from household waste, as they contain harmful substances and valuable resources. They can be disposed of at an approved collection or take-back point, e.g. a local recycling center. Old appliances, batteries and rechargeable batteries are accepted there free of charge and recycled in an environmentally friendly and resource-saving manner. Old electrical appliances, used batteries or rechargeable batteries can also be returned to us. The return shipment must be sent with sufficient postage to the address below. The following symbol on waste electrical equipment, batteries or rechargeable batteries indicates that they must not be disposed of with household waste:



### Important notes on the use of batteries:

- The use of high-quality brand batteries is essential for the correct functioning of the locking system. BURG locking systems are approved ex works for the specified industrial batteries of the VARTA brand. The use of batteries of other brands can lead to a reduced number of possible locking cycles as well as to limited functionality and functional problems, as experience has shown that batteries of other brands even with the same specifications have different performance characteristics. BURG does **not guarantee** the functionality of the locking system when using batteries of a brand other than those specified above.
- If both batteries are removed at the same time when changing the batteries or over a longer period of time, settings relating to the integrated real-time clock (RTC) will be lost.
- The battery may explode or release flammable gases if it is handled incorrectly, destroyed or the wrong type of battery is used. Do not recharge the battery, disassemble it, expose it to extremely high temperatures or throw it into a fire. Batteries containing harmful substances are labeled with abbreviations for the substances cadmium (*Cd*), mercury (*Hg*) and lead (*Pb*). If the lock is not used for a longer period of time, the batteries must be removed.

## Information on battery life



For online viewing,  
click on QR codes.

## Conformity / Certification

### CE Declaration of Conformity

Hereby, **BURG Lüling GmbH & Co. KG** declares that the radio equipment, type **Flexo.RFID**, is in conformity with directives 2014/53/EU and 2011/65/EU. The full text of the EU Declaration of Conformity can be found at the following link:



[https://www.burg.de/files/downloads/Declaration-of-Conformity/BURG\\_DoC\\_FlexoRFID\\_EN.pdf](https://www.burg.de/files/downloads/Declaration-of-Conformity/BURG_DoC_FlexoRFID_EN.pdf)

## Guarantee and Warranty

The warranty is subject to the statutory provisions. If you have any questions, please contact a specialist dealer or use the contact details below. Spare parts can be found at specialist dealers or at: **www.burg.shop**

## Cleaning and Care Instructions

Remove the batteries before cleaning the appliance. Carefully clean the surfaces of the appliance with a damp, clean cloth. Chemical cleaning agents must not be used. Do not allow dust or liquids to enter the device.

## Contact

### BURG Lüling GmbH & Co. KG

Volmarsteiner Str. 52  
58089 Hagen (Germany)  
+49(0)2335 6308-0

info@burg.de  
www.burg.de