

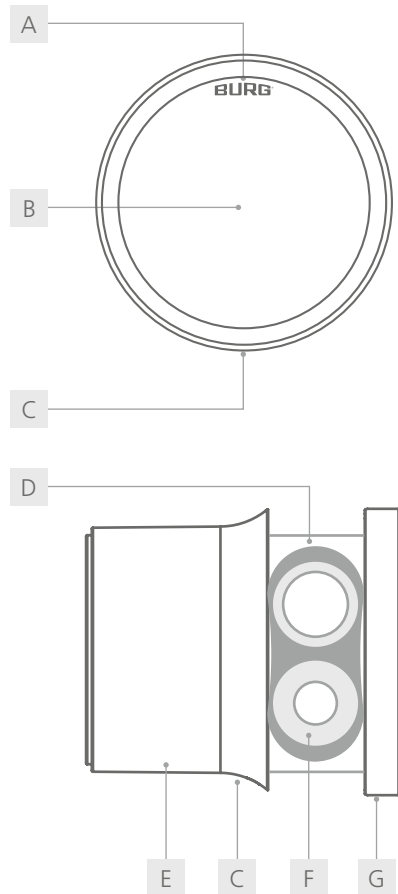

Flexo.Cloud  
Operating Manual

## MasterPro



- |                   |                       |
|-------------------|-----------------------|
| A LED light ring  | B RFID antenna        |
| C closure hole    | D battery compartment |
| E housing         | F battery             |
| G operating panel |                       |

## General

The latest version of this guide is available at:  
[www.burg.de](http://www.burg.de)

### Important notes:

- Please observe all important notes and read the entire operating manual before starting the configuration.
- Before putting the locking system into operation, refer to "Commissioning" on page 5 and 6 and check the battery capacity. (For help, see "Battery warning" on page 5.)
- Master cards must be kept in a safe place. If lost, no further configurations can be made.

## Content

General.....	2
Technical data.....	3
Default settings.....	3
Scope of delivery.....	3
Optional accessories.....	3
Features.....	3
Mounting dimensions.....	4
Product dimensions.....	4
Functional description.....	5
App myBURG.....	5
LED signals.....	6
Guarantee of transponder compatibility.....	6
Commissioning.....	6 - 7
Authorization levels.....	7
Configuration.....	7 - 8
Operation.....	8
Assembly RetroFit.....	9
Assembly FlushFit.....	10
Battery change with Flexo.Tool.....	11
Battery change with opening needle.....	12
Disposal and battery note.....	13
Information on battery life.....	13
Guarantee and warranty.....	13
Cleaning and care instructions.....	13
Contact.....	13

To the video:  
**assembly (FlushFit)**



To the video:  
**assembly (RetroFit)**



For online viewing, click on QR codes.

# Factsheet

## Front view



## Back view



Technical Data	
Dimension	Ø 50 mm
Battery <sup>1</sup>	VARTA <sup>1</sup> 1/2 AAH-R (2x) 850 mAh, CR High Power
Locking cycles	up to 15.000 <sup>2</sup>
Material	housing: plastic stator: zamak
Temperature range	working temperature: 5°C bis 50°C
Application area	Indoor
Mounting dimension	RetroFit: 16 mm x 19 mm FlushFit: 44,55 mm x 46,5 mm
Max. door thickness	22 mm
Lock attachment	RetroFit: M19 Mutter (1x) FlushFit: Flexo.Mutter (1x)
Cam type	B
Locking direction	left (90°), door hinge: DIN right right (90°), door hinge: DIN left
Mode	Multi-user mode, Private mode light, Private mode (App), Shared private mode (App)
RFID types	ISO 14443 A (e.g. MIFARE®), LEGIC® Prime, LEGIC® Advant
No. of master cards	max. 1
No. of manager cards	max. 3
Radio modulation	Bluetooth® Low Energy: GFSK
Radio frequency	13,56 MHz / 2,4 - 2,4835 GHz
Transmission power	345 mW / +4 dBm
Radio range	50 mm / 20 m
Power consumption	max. 180 mA

Default Settings	
Mode	multi-user mode

### Scope of Delivery

- 1x locking system
- 1x cam fixing screw <sup>3</sup> (M6 x 12 mm)
- 1x M19 nut (Assembly: RetroFit)
- 1x Flexo.Ring (mounted) / Flexo.Nut (Assembly: FlushFit)

### Optional Accessories

- Battery (VARTA <sup>1</sup> 1/2 AAH-R)
- anti-twist protection (W-MSZ-01)
- master card
- manager card
- user card
- opening needle / Flexo.Tool
- cam type B (order-related)

### Features

- flexible operation via RFID and the app
- easy lock management and configuration via the app
- secure end-to-end encryption (Bluetooth®)
- integrated LED light ring for user feedback
- external battery access and battery replacement
- easy retrofitting, e.g., to replace mechanical locks
- adjustable cam (in 90° steps)

<sup>1</sup> The lock is approved for VARTA brand batteries. The use of other batteries may lead to malfunctions (s. point „battery note“).

<sup>2</sup> Test value for consecutive locking cycles with one set of VARTA batteries. In everyday use, factors such as usage profile, temperature-dependent self-discharge, battery quality, and the standby current of the electronics limit the achievable number of cycles. The actual number may therefore vary. For further information, see p. 12 "Information on battery life".

<sup>3</sup> The use of a screw with a different length may cause damage to the lock.

## Mounting Dimensions <sup>1</sup>

All dimensions are in millimeters.

FlushFit

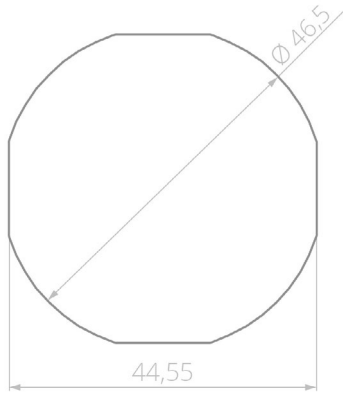

RetroFit 16x19 mm

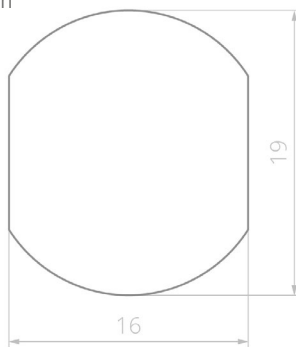

## Product Dimensions <sup>1</sup>

Frontview

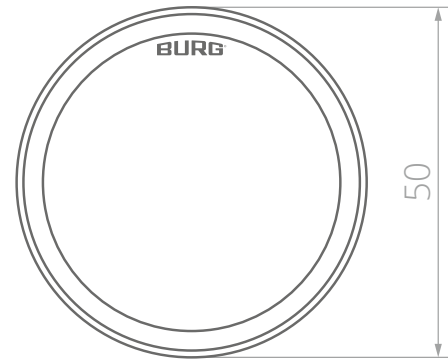

Sideview

FlushFit

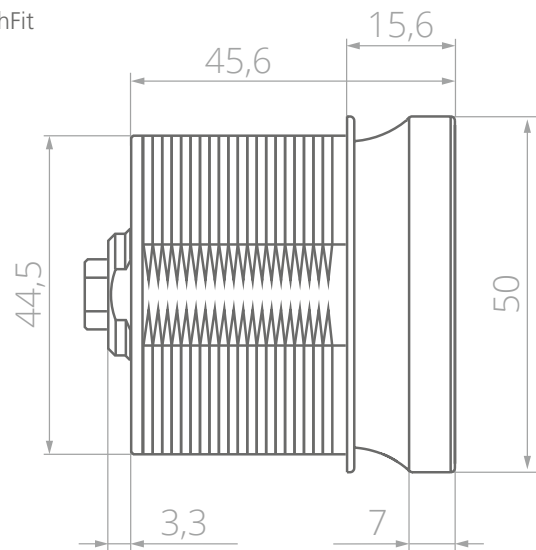

RetroFit 16x19 mm

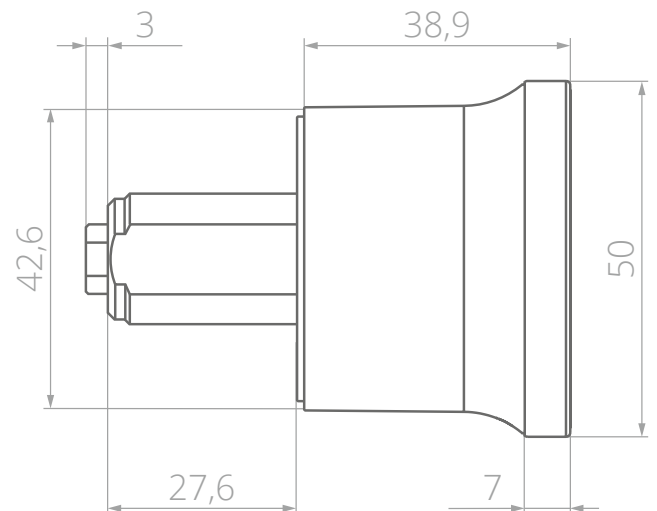

<sup>1</sup> Mounting dimensions and templates (STEP files) for milling, punching or lasering can be requested from BURG.

## Functional description

### Mode: multi-user mode

This mode is suitable for changing user groups where the locker is only used temporarily or once. Transponder media are valid for a single locking process and are deleted from the lock when the compartment is reopened. The lock remains open until a new transponder medium locks the lock again.

### Mode: private mode light

In this mode, the lock is permanently assigned to a person who can operate it. This mode is suitable for user groups where usage rights are not expected to change permanently, e.g., for an office cabinet. A personalized lock can get personalized again at any time.

### Mode: private mode (App)

In this mode, the lock is permanently assigned to one person who can operate it. This mode is suitable for user groups where usage rights are not expected to change permanently, e.g., for an office cabinet. This private mode can only be used via the app and is a requirement for using shared private mode.

### Mode: shared private mode (App)

In this mode, the lock is personalized and shared with a person or group of people. Access is enabled via the app. The lock remains in the possession of the person who personalized it. This person can remove access at any time or authorize access for other people.

### Master card

The master card authorizes the assignment and removal of manager cards. A maximum of one master card can be assigned, which can only be removed by resetting the lock. The master card does not have an opening or closing function.

### Manager card

At least one manager card should be assigned to a lock or stored in the app; a maximum of three are possible. Regardless of the mode set, the lock can be opened with the manager card (emergency opening). In multi-user mode, the transponder medium used for closing is deleted from the lock. The manager card has no locking function.

### Automatic locking (in private mode App)

After opening, the lock closes automatically after four seconds.

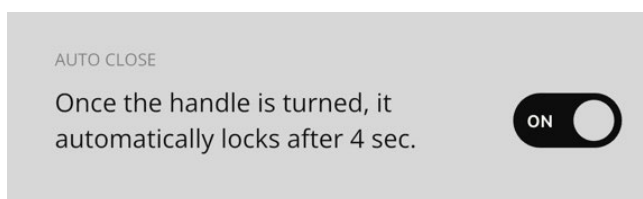

### Battery warning

If the battery voltage falls below a certain level (*phase 1*), the **yellow LED** flashes **3x** after an opening or closing operation. The lock can only be operated a few more times. If the voltage drops further (*phase 2*), the **red LED** flashes in a rotating pattern. The administrator can view the battery voltage status of the lock via the app.

## App myBURG

The "myBURG" app (iOS/Android) offers a central locking and opening function for Cloud locks. It can be used in multi-user mode, private mode (app), and shared private mode (app).

### For users

The intuitive, user-friendly app makes it easy to admin, personalize, or share individual locks or entire lock groups:

- key function: locking & opening
- admin personalized locks (private mode and shared private mode)
- overview of your own locks
- conveniently perform firmware updates in the background

### For admins

The administrator has an overview of all assigned locks and can administrate and maintain them and read activity information:

- administrator access
- administrate and maintain locks
- assign authorizations
- emergency opening of all locks within the lock group

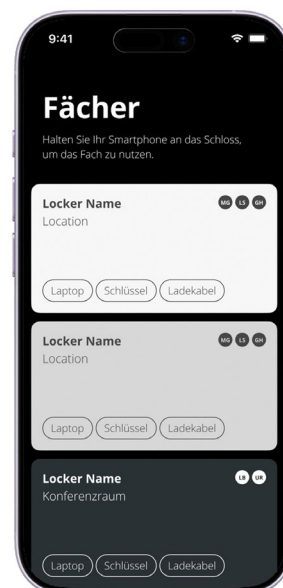

App store: **Apple iOS**



App store: **Android**

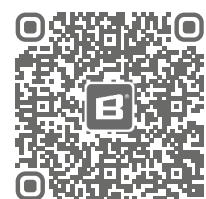

For online viewing, click on QR codes.

## LED signals

### 1x green LED

Successful opening/closing process with transponder media or smartphone.

Successful emergency opening with manager card.

### 2x green LED

Opening/closing process with active "Auto Close" function.

### 3x green LED

Successful commissioning with battery and after battery replacement.

Successful reset of the lock.

### Green rotating light

Ongoing firmware update.

### 1x green LED and 1x red LED

Assigning or presenting of a master card.

### 1x red LED

Rejecting unauthorized transponder media.

Canceling a configuration process.

### 3x yellow LED

The lock can only be operated a few more times.

The battery should be replaced soon.

### Red rotating light

The battery is empty.

## Guarantee of Transponder Compatibility

When using RFID transponder media that have not been approved by BURG, no guarantee of compatibility is given.

## Commissioning

- The first card held in front of the lock during commissioning or after a reset is automatically stored as the master card.
- When commissioning, it is absolutely necessary to assign the lock to an administrator via the app or with the master card.
- After commissioning, we recommend assigning at least one manager card and keeping it in a safe place.

### 1 Insert batteries

1. Remove the lock from packaging and open the battery compartment (for help, see page **11/12** "Battery change").
2. Insert the batteries according to the (+ / -) symbols. Wait for the **green** LED to flash **3x**. Close the battery compartment.

### 2 Master card

#### a) Assigning without an app (physical cards)

1. Hold the designated master card **1x** in front of the knob. The LED will light up **1x green** and **1x red**.
2. Hold the master card **1x** again in front of the knob. The LED lights up **1x green** and **1x red**.

#### b) Storing in the app

- A maximum of one master card can be stored.
- During this process, the master card is stored in the app. The lock serves as a transmission medium between the app and the card. The stored cards are not saved on the lock.

1. Open the app and your personal profile. (bottom row, 4th icon)
2. Open "Saved admin cards".
3. Select the "Add cards" button and first select master card.
4. Follow the instructions in the myBURG app.

### 3 Manager card

#### a) Assigning without an app (physical cards)

1. Hold the master card **1x** in front of the knob. The LED lights up **1x green** and **1x red**.
2. Hold the designated manager card **1x** in front of the knob. The LED will light up **1x green** and **1x red**.
3. If necessary, hold additional manager cards **1x** in front of the knob.
4. To finish, hold the master card **1x** in front of the knob. The LED lights up **1x green**.

*Note: A total of **3** manager cards can be stored.*

#### b) Delete without an app

1. Hold the master card **1x** in front of the knob. The LED lights up **1x green** and **1x red**.
2. Hold the manager card to be deleted in front of the knob for approx. **10 seconds**. At the start, the LED lights up **1x green**. After 10 sec., the **red** LED lights up **1x**.
3. If necessary, hold additional manager cards **1x** in front of the knob.
4. To finish, hold the master card **1x** in front of the knob. The LED lights up **1x green**.

## c) Storing in the app

- A maximum of 3 manager cards can be stored.
- During this process, the manager card is stored in the app. The lock serves as a transmission medium between the app and the card. The stored cards are not saved on the lock.

1. Open the app and your personal profile. (bottom row, 4th icon)
2. Open "Saved admin cards".
3. Select the "+ New card" button and select manager card.
4. Follow the instructions in the myBURG app.

## b) Delete in the app

1. Open the app and your personal profile. (bottom row, 4th icon)
2. Open "Saved admin cards".
3. Select the "Delete card" button above the card image.
4. Confirm "Delete card" in the pop-up window.

## 4 Set up locks in the app

In order to set up locks in the app, you must first complete the previous steps and save the master and manager cards in your app. (See point 2 Master cards and point 3 Manager cards)

1. Open the app and open the organization tab. (bottom row, 2nd icon)
2. Click the "Set up a lock" button.
3. Follow the instructions in the myBURG app.

*Note: The lock is now stored in the app but remains in multi-user mode until this is changed by the administrator or a user requests personalization (chapter: Configuration, 1. Set modes "Private mode (app)").*

## Authorization levels

### Administrator

Main administrator of the lock / multiple locks (e.g., facility manager). Can grant access to the locks for main users on request and open the locks in an emergency.

### Main user / owner

Can request locks for private mode (app) from the administrator and becomes a temporary "owner." Can share the personalized lock with other people (group members) (shared private mode (app)).

### Group members

Can use shared locks, but cannot grant permissions.

## Configuration

### 1 Set modes

The default setting for the lock is multi-user mode. The lock must also be in this mode if it is to be switched to another mode.

#### a) Set private mode light

1. Hold the desired user card for **6 seconds** in front of the knob. At the start, the LED lights up **1x green**. After 6 sec., the LED lights up **1x green** and **1x red**.
2. Hold the user card **1x** again in front of the knob. The LED lights up **1x green**

*Note: The lock can only be operated with the stored user card. After an emergency opening, the personalization expires and the lock returns to multi-user mode. If the manager card is held up while the lock is open, the personalization also expires.*

#### b) Turn off private mode light (via user card)

1. Hold the stored user card for **6 seconds** in front of the knob. At the start, the LED lights up **1x green**. After 6 sec., the LED again lights up **1x green**.

*Note: The lock is set to multi-user mode again.*

#### c) Turn off private mode light (via manager card)

1. Hold the manager card **1x** in front of the knob. The LED lights up **1x green**.

*Note: The lock can be either open or closed for this process (e.g., emergency opening).*

#### d) **Privat mode (App)** (request personalization)

1. Lock the lock in multi-user mode via the app.
2. Select the lock on the app's home screen.
3. Click on the "Request to personalise" button.
4. The administrator receives a notification about the request and can approve it in their app.

*Note: The app may take a few seconds to update the personalization. The lock can only be operated by the authorized user account (smartphone).*

#### e) **Privat mode (App)** (Return locker)

1. Select the lock on the app's home screen.
2. Click on the "Return locker" button.

*Note: The lock is set to multi-user mode again.*

#### f) **Shared private mode (App)**

1. The lock must be in private mode (app) (chapter: Configuration, 2. Set modes, "Private mode (App)").
2. Select the lock on the app's home screen.
3. Click on the "+ Invite person" button and select the desired people.
4. Follow the instructions in the myBURG app.

*Note: Only the administrator can use their master card and manager cards to open and reset the lock in an emergency. The main user (who requested the lock for private mode (app)) remains the temporary owner until they release the lock again.*

## 2 Store user card

With a user card stored in the app, a lock can be operated both with this user card and with the app. This is helpful in case the user card is not available at the moment.

1. Open the app and your personal profile. (bottom row, 4th icon)
2. Open "Saved admin cards".
3. Select the "+ New card" button and select user card.
4. Follow the instructions in the myBURG app.

## 3 Auto close (in private mode (app))

1. Select the lock on the app's home screen.
2. Activate „Auto Close“.
3. Follow the instructions in the myBURG app.

*Note: The lock now locks after 4 seconds. After using the compartment, it is recommended to close the door / compartment again and turn the lock to the closed position (logo is at the top).*

## 4 Reset to default settings

This process deletes all cards stored on the lock (master card, manager card, user card) – **including the master card used for this process.**

1. Hold the master card for **30 seconds** in front of the knob. The LED lights up **1x green** and **1x red**.
2. After the 30 seconds, the **green** LED lights up **1x** and then, after a short pause, **3x** more.
3. After the LED has lit up **green 3x**, the lock can be reprogrammed and a master card can be assigned.

## Operation

Unauthorized transponder media are rejected by the lock with **1x** flashing of the **red** LED.

### a) Lock

1. Hold your user card or smartphone with the opened app in front of the knob. The LED will light up **1x green**.
2. The lock is locked.

### b) Unlock

1. Hold the user card or smartphone with the opened app in front of the previously locked knob. The LED will light up **1x green**.
2. Turn the knob and open the compartment.

## Assembly RetroFit

Mounting dimensions and templates (STEP files) for milling, punching or lasering can be requested from BURG.

- 1 Prepare the mounting holes on the door front according to the installation dimensions (dimensions on p. 4).

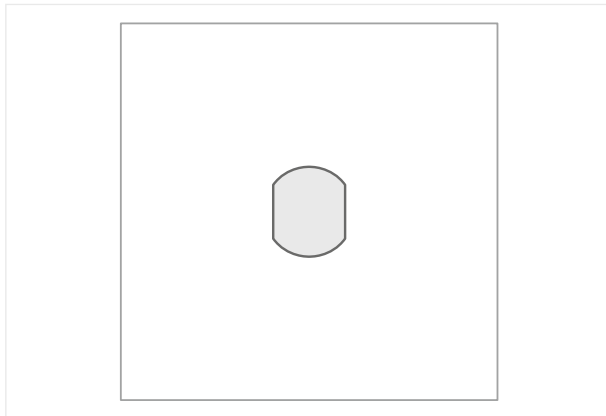

- 2 Insert the lock from the front (outside of the door) into the mounting hole and hold it in this position. The lock must be straight and the BURG logo must be at the top.

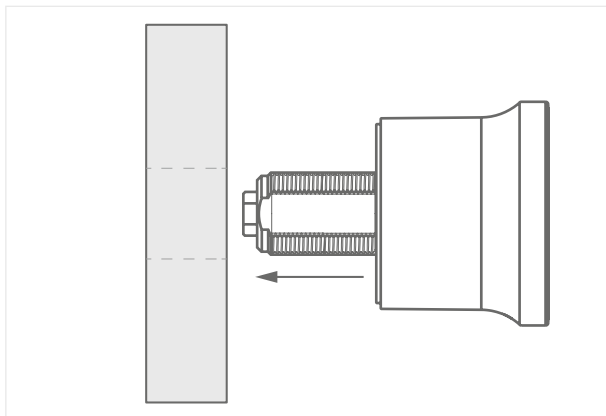

- 3 Place the M19 nut on the stator from behind and tighten it by hand using a socket wrench (SW22).

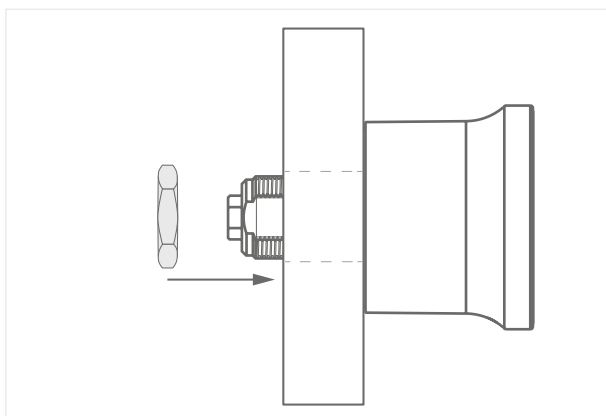

- 4 Attach the cam. Tighten it by hand using the cam fixing screw and a cross-head screwdriver (e.g., size PH 2).

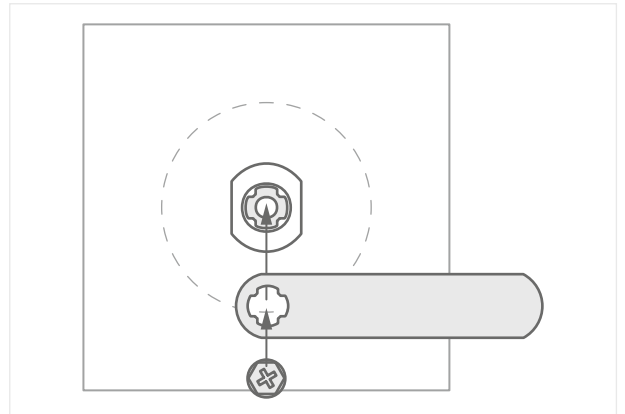

- 5 Check whether the cam is securely held in place on the strike plate or rebate when closed. When closing the locking system, it should be possible to turn the cam to its end position without applying pressure or resistance.

*Note: An adjustable strike plate allows for optimal adjustment of the closing mechanism. More information can be requested from BURG.*

To the video:  
**assembly (RetroFit)**



For online viewing,  
click on QR codes.

## Montage FlushFit

Mounting dimensions and templates (STEP files) for milling, punching or lasering can be requested from BURG.

- 1 Prepare the mounting holes on the door front according to the installation dimensions (dimensions on p. 4).

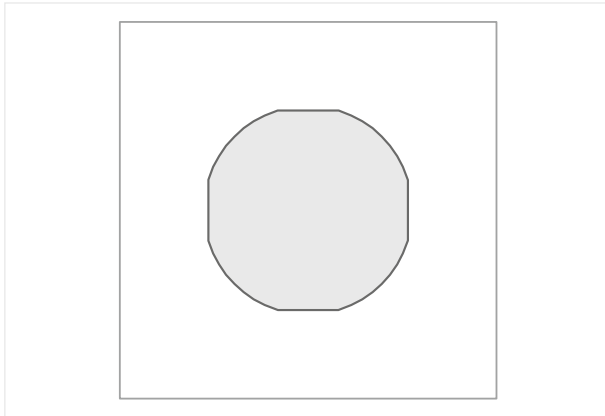

- 2 Insert the Flexo.Ring from the front (outside of the door) into the mounting hole and secure it with the ring nut.

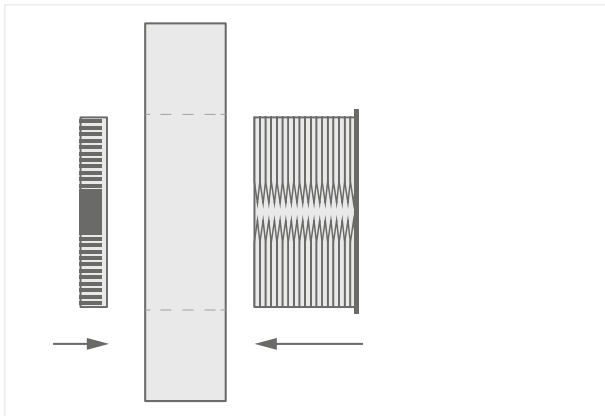

- 3 Insert the lock from the front (outside of the door) into the mounting hole and hold it in this position. The lock must be straight and the BURG logo must be at the top.

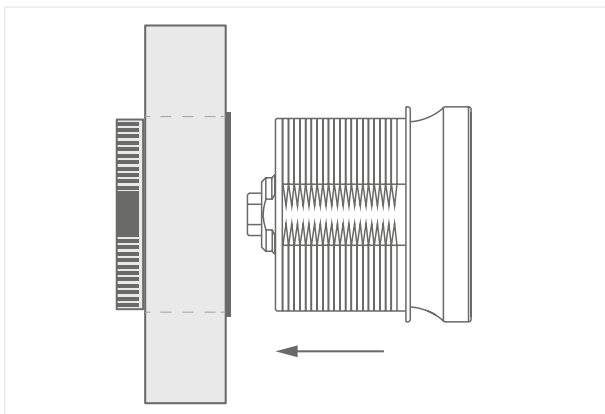

- 4 Place the Flexo.Nut on the stator from behind and tighten it by hand using a socket wrench (SW22).

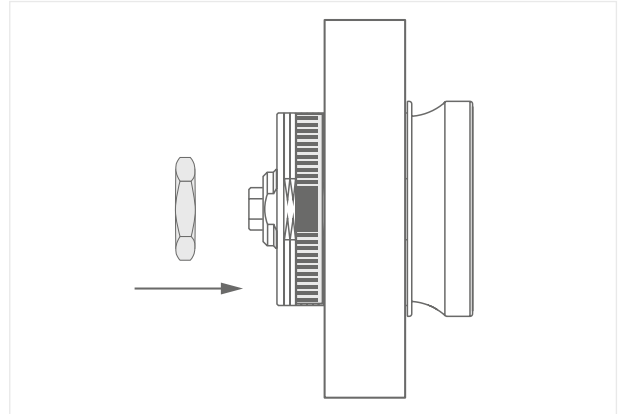

- 5 Attach the cam. Tighten it by hand using the cam fixing screw and a cross-head screwdriver (e.g., size PH 2).

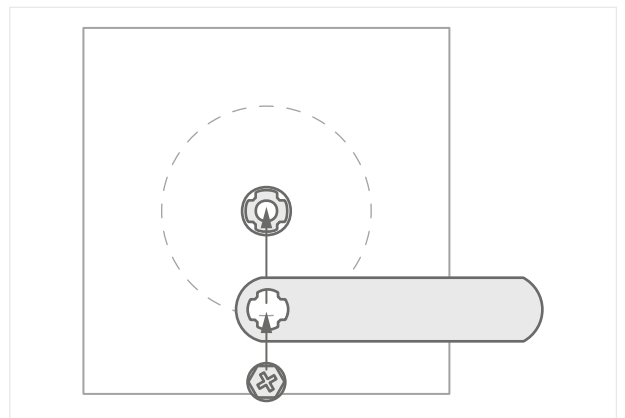

Check whether the cam is securely held in place on the strike plate or rebate when closed. When closing the locking system, it should be possible to turn the cam to its end position without applying pressure or resistance.

*Note: An adjustable strike plate allows for optimal adjustment of the closing mechanism. More information can be requested from BURG.*

To the video:  
**assembly (FlushFit)**



For online viewing,  
click on QR codes.

## Battery Change with Flexo.Tool

The Flexo.Tool is required for this battery change option. To open the battery compartment, simply twist the housing (shown as the gray area in the sketches).

- 1 When disassembled, the lock must be held in place on the stator. When assembled, the lock does not need to be held in place.

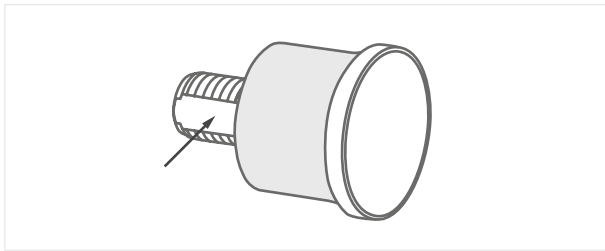

- 2 Carefully insert Flexo.Tool into the hole below the control unit until you feel resistance, then press lightly.

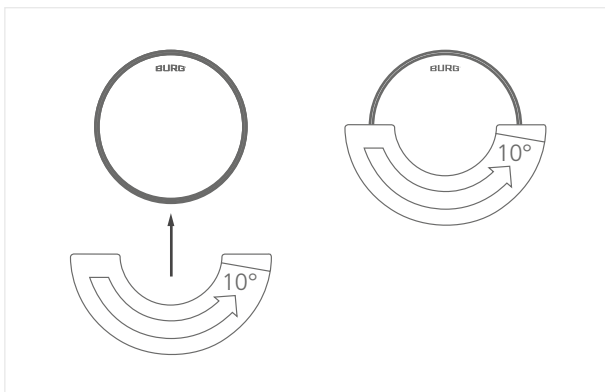

- 3 Hold Flexo.Tool in position and turn the tool with the housing (see sketch 1 above) approximately 10° counterclockwise. The control panel is not turned during this process.

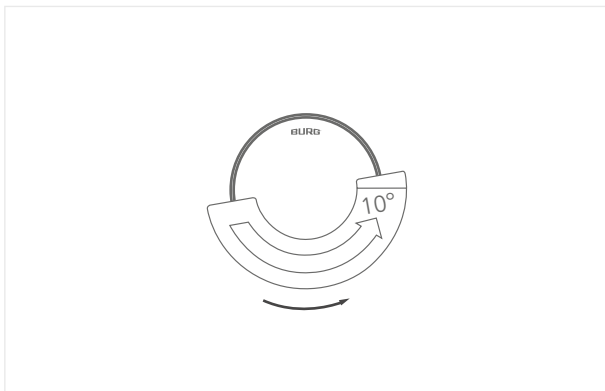

- 4 Remove Flexo.Tool and pull the control panel forward.

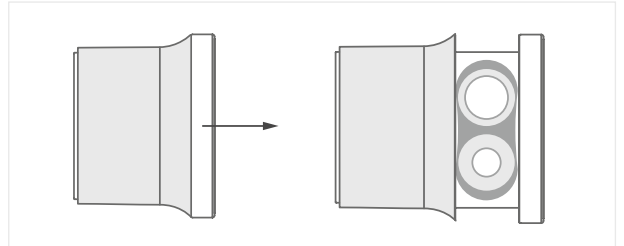

- 5 Remove the battery compartment cover. Replace the batteries according to the (+/-) symbols and replace the battery compartment cover.

- 6 Push the control panel back. Carefully turn the housing clockwise back until it clicks into place.

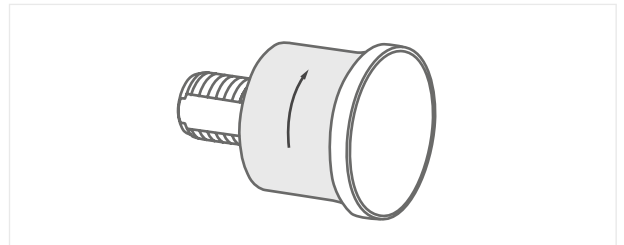

To the video:  
**Battery change**



For online viewing,  
click on QR codes.

## Battery Change with opening needle

The opening needle is required for this battery change option. To open the battery compartment, simply twist the casing (shown as the gray area in the sketches).

- 1 When disassembled, the lock must be held in place on the stator. When assembled, the lock does not need to be held in place.

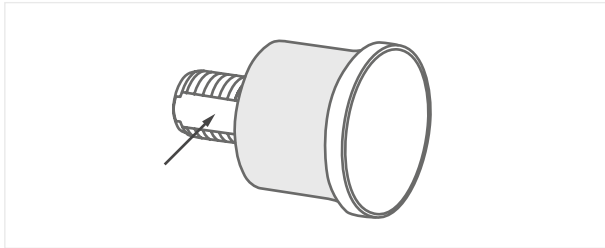

- 2 Carefully insert the opening needle into the hole below the control unit until you feel resistance, then press lightly.

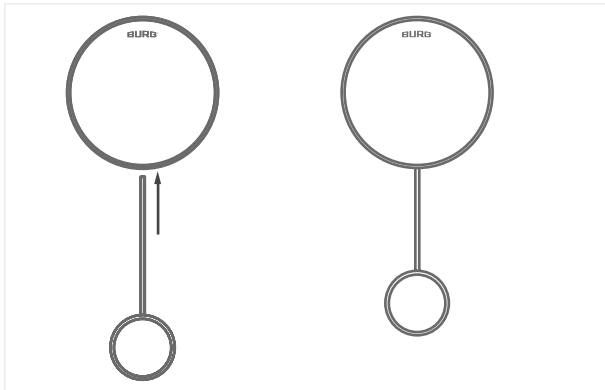

- 3 Hold the opening needle in position and turn the needle with the housing (see sketch 1 above) approximately 10° counterclockwise. The control panel is not turned during this process.

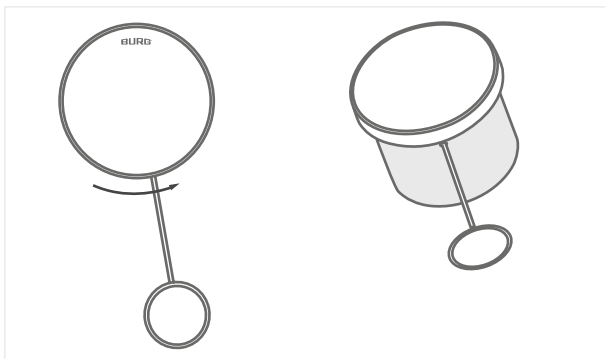

- 4 Remove the opening needle and pull the control panel forward.

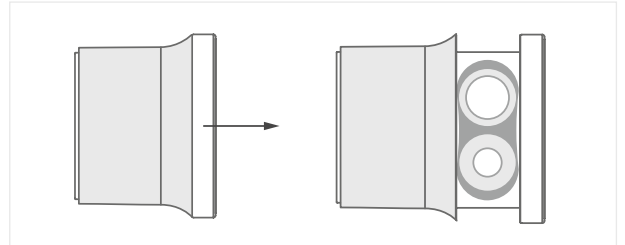

- 5 Remove the battery compartment cover. Replace the batteries according to the (+/-) symbols and replace the battery compartment cover.

- 6 Push the control panel back. Carefully turn the housing clockwise back until it clicks into place.

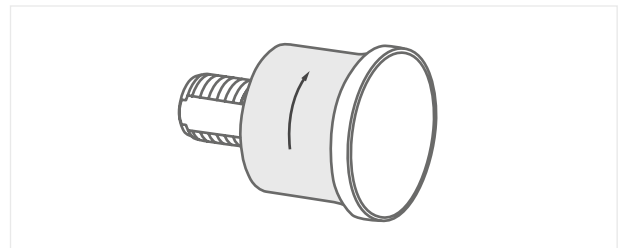

To the video:  
**Battery change**<sup>1</sup>



For online viewing,  
click on QR codes.

## Disposal and Battery Note

EU Directive 2012/19/EU regulates the proper take-back, treatment and recycling of used electronic devices.

Every consumer is legally obliged to dispose of batteries, rechargeable batteries or electrical and electronic devices ("old devices") that are powered by batteries or rechargeable batteries separately from household waste, as they contain harmful substances and valuable resources. They can be disposed of at an approved collection or take-back point, e.g. a local recycling center. Old appliances, batteries and rechargeable batteries are accepted there free of charge and recycled in an environmentally friendly and resource-saving manner. Old electrical appliances, used batteries or rechargeable batteries can also be returned to us. The return shipment must be sent with sufficient postage to the address below. The following symbol on waste electrical equipment, batteries or rechargeable batteries indicates that they must not be disposed of with household waste:



### Important notes on the use of batteries:

- The use of high-quality brand batteries is essential for the correct functioning of the locking system. BURG locking systems are approved ex works for the specified industrial batteries of the VARTA brand. The use of batteries of other brands can lead to a reduced number of possible locking cycles as well as to limited functionality and functional problems, as experience has shown that batteries of other brands even with the same specifications have different performance characteristics. BURG does **not guarantee** the functionality of the locking system when using batteries of a brand other than those specified above.
- If both batteries are removed at the same time when changing the batteries or over a longer period of time, settings relating to the integrated real-time clock (RTC) will be lost.
- The battery may explode or release flammable gases if it is handled incorrectly, destroyed or the wrong type of battery is used. Do not recharge the battery, disassemble it, expose it to extremely high temperatures or throw it into a fire. Batteries containing harmful substances are labeled with abbreviations for the substances cadmium (*Cd*), mercury (*Hg*) and lead (*Pb*). If the lock is not used for a longer period of time, the batteries must be removed.

## Information on battery life



For online viewing,  
click on QR codes.

## Conformity / Certification

### CE Declaration of Conformity

Hereby, **BURG Lüling GmbH & Co. KG** declares that the radio equipment, type **Flexo.Cloud**, is in conformity with directives 2014/30/EU, 2014/35/EU, 2014/53/EU and 2011/65/EU. The full text of the EU Declaration of Conformity can be found at the following link:



[https://www.burg.de/files/downloads/Declaration-of-Conformity/BURG\\_DoC\\_FlexoCloud\\_EN.pdf](https://www.burg.de/files/downloads/Declaration-of-Conformity/BURG_DoC_FlexoCloud_EN.pdf)

## Guarantee and Warranty

The warranty is subject to the statutory provisions. If you have any questions, please contact a specialist dealer or use the contact details below. Spare parts can be found at specialist dealers or at: **www.burg.shop**

## Cleaning and Care Instructions

Remove the batteries before cleaning the appliance. Carefully clean the surfaces of the appliance with a damp, clean cloth. Chemical cleaning agents must not be used. Do not allow dust or liquids to enter the device.

## Kontakt

### BURG Lüling GmbH & Co. KG

Volmarsteiner Str. 52  
58089 Hagen (Germany)  
+49(0)2335 6308-0

info@burg.de  
www.burg.de